

iN90 LED

IT ATTENZIONE:

LA SICUREZZA DELL'APPARECCHIO E' GARANTITA SOLO CON L'USO APPROPRIATO DELLE SEGUENTI ISTRUZIONI; PERTANTO E' NECESSARIO CONSERVARLE.

EN WARNING:

THE SAFETY OF THIS FIXTURE IS GUARANTEED ONLY IF YOU COMPLY WITH THESE INSTRUCTIONS; REMEMBER TO CONSERVE IN A SAFE PLACE.

FR ATTENTION:

LA SECURITE DE L'APPAREIL N'EST GARANTIE QU'EN CAS D'UTILISATION CORRECTE DES INSTRUCTIONS SUIVANTES; IL FAUT PAR CONSEQUENT LES CONSERVER.

DE ACHTUNG:

DIE SICHERHEIT DES GERÄTES WIRD NUR DURCH SACHGEMÄSSE BEFOLGUNG NACHSTEHENDER ANWEISUNGEN GEWÄHRLEISTET; IHRE AUFBEWAHRUNG IST DESHALB SEHR WICHTIG.

NL OPGELET:

DE VEILIGHEID VAN DI ATOESTEL IS SLECHTS DAN GEGARANDEERD ALS INDIEN DE VOLGENDE INSTRUCTIES STRIKT WORDEN TOEGEPAST: DAAROM MOET MEN ZE OOK BEWAREN.

ES ATENCION:

LA SEGURIDAD DEL APARATO SE GARANTIZA SOLO CUMPLIENDO CUIDADOSAMENTE LAS SIGUIENTES INSTRUCCIONES; POR ELLO, ES NECESARIO CONSERVARLAS.

DA BEMÆRK:

SIKKERHEDEN VED BRUG AF ARMATURET KAN KUN GARANTERES, HVIS DISSE ANVISNINGER FØLGES; SØRG DERFOR FOR AT GEMME DEM.

NO ADVARSEL:

SIKKERHETEN TIL DETTE APPARATET GARANTERES KUN HVIS DU OVERHOLDER DISSE INSTRUKSJONENE; HUSK Å OPPBEVARE DEM PÅ ET TRYGT STED.

SV OBSERVERA!

UTRUSTNINGENS SÄKERHET KAN ENDAST GARANTERAS OM DESSA ANVISNINGAR RESPEKTERAS I DETALJ. SPARA DÄRFÖR DESSA ANVISNINGAR FÖR FRAMTIDA KONSULTATION.

RU ВНИМАНИЕ:

МЫ ГАРАНТИРУЕМ БЕЗОПАСНУЮ ЭКСПЛУАТАЦИЮ ИЗДЕЛИЯ ТОЛЬКО ПРИ СОБЛЮДЕНИИ СПЕДУЮЩИХ ИНСТРУКЦИЙ; С ЭТОЙ ЦЕЛЬЮ НЕОБХОДИМО СОХРАНИТЬ ДАННУЮ БРОШЮРУ.

ZH 警告

为确保该装置安全，请遵守操作指示；并于安全场所放置。

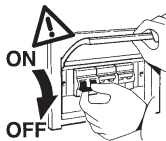

N.B.: DURANTE L'INSTALLAZIONE DEL SISTEMA "iN 90 LED" RISPETTARE SCRUPOLOSAMENTE LE NORME IMPIANTISTICHE NAZIONALI VIGENTI.

N.B.: WHEN INSTALLING THE "iN 90 LED" SYSTEM, MAKE SURE ALL CURRENT NATIONAL REGULATIONS RELATING TO INSTALLATION ARE OBSERVED.

N.B.: LORS DE L'INSTALLATION DU SYSTÈME "iN 90 LED" VEUILLEZ RESPECTER RIGOREUSEMENT LES NORMES EN VIGUEUR EN LA MATIÈRE DANS LE PAYS.

N.B.: BEACHTEN SIE BEI DER INSTALLATION DES SYSTEMS "iN 90 LED" UNBEDINGT DIE IM LAND GELTENDEN ANLAGETECHNISCHEN VORSCHRIFTEN.

N.B.: BIJ HET INSTALLEREN VAN HET "iN 90 LED" SYSTEEM MOET U DE GELDENDE NATIONALE INSTALLATIENORMEN STRIKT NALEVEN.

NOTA: DURANTE LA INSTALACIÓN DEL SISTEMA "iN 90 LED" RESPETAR ESCRUPULOSAMENTE LAS NORMAS NACIONALES DE INSTALACIÓN EN VIGOR.

N.B.: UNDER INSTALLATION AF "iN 90 LED" SYSTEMET SKAL MAN NØJE OVERHOLDE DE GÆLDENDE REGLER FOR DISSE ANLÆG.

N.B.: UNDER INSTALLASJON AV SYSTEMET "iN 90 LED" MÅ DE NASJONALE ANLEGGSFORSKRIFTENE OVERHOLDES NØYE.

OBS! UNDER INSTALLATIONEN AV SYSTEMET "iN 90 LED" SKA GÄLLANDE NATIONELLA INSTALLATIONSFÖRESKRIFTER RESPEKTERAS I DETALJ.

ПРИМЕЧАНИЕ: В ПРОЦЕССЕ МОНТАЖА СИСТЕМЫ "iN 90 LED" СТРОГО СОБЛЮДАЙТЕ НАЦИОНАЛЬНЫЕ ДЕЙСТВУЮЩИЕ НОРМАТИВЫ ПО ЭЛЕКТРОПРОВОДКЕ.

重要：安装 "iN 90 LED" 系统时请始终参照标准系统

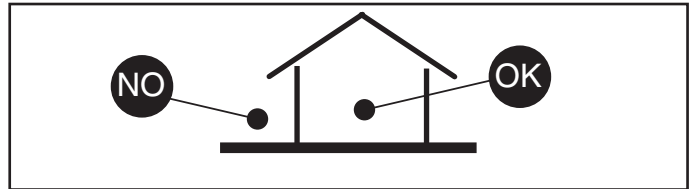

INSTALLAZIONE SUL CONTROSOFFITTO
INSTALLATION ON CEILING
INSTALLATION AU FAUX-PLAFOND
INSTALLATION AN DER HÄNGEDECKE
HET INSTALLEREN IN HET VERLAAGDE PLAFOND
INSTALACION SOBRE FALSO TECHO
INSTALLATION PÅ FORSÆNKET LOFT
MONTERING I TAKET
INSTALLATION I UNDERTAK
МОНТАЖ В ФАЛЬШ-ПОТОЛКЕ
吸顶式安装天花板上的安装

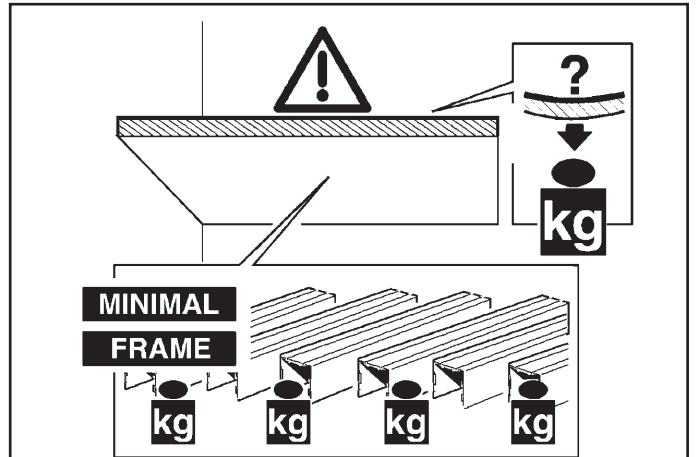

IT N.B.: E' responsabilità dell'utente verificare la resistenza del controsoffitto, in funzione del peso degli apparecchi installati.

EN N.B.: It is the user's responsibility to check the strength of the false ceiling with respect to the weight of the fixtures installed.

FR N.B.: Il appartient à l'utilisateur de vérifier la résistance du faux plafond en fonction du poids des appareils installés.

DE N.B.: Es obliegt dem Verbraucher sicherzustellen, daß die Deckenverkleidung das Gewicht der Einbauleuchte aufnehmen kann.

NL N.B.: Het is de verantwoordelijkheid van de koper zich ervan te verzekeren dat het verlaagde plafond stevig genoeg is voor het dragen van het gewicht van de geïnstalleerde apparaten.

ES NOTA: Corresponde al usuario efectuar las pruebas en el falso techo, en función del peso de los aparatos instalados.

DA N.B.: Det er brugerens ansvar, at kontrollere loftets modstandsdygtighed, ud fra de installerede apparaters vægt.

NO N.B.: Det er brukerens ansvar å kontrollere himlingens/takets motstandskraft, på grunnlag av de installerte apparatens vekt.

SV OBS! Det är användarens ansvar att kontrollera takets hållfasthet i förhållande till vikten på installerad utrustning.

RU ПРИМЕЧАНИЕ: Пользователь должен проверить прочность фальш-потолка в соответствии с весом устанавливаемых в него приборов.

ZH 注意：用户须根据安装装置的重量 检查天花板的强度。

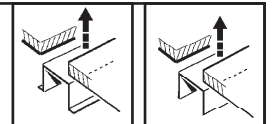

IT N.B.: Apparecchi non idonei ad essere coperti di materiale termicamente isolante

EN N.B.: Fixtures not suitable to be covered in thermally-insulating material.

FR N.B.: Appareils ne pouvant pas être couverts de matériau d'isolation thermique

DE N.B.: Geräte nicht geeignet, um mit wärmeisolierendem Material abgedeckt zu werden

NL N.B.: Deze apparaten zijn niet geschikt om te worden bedekt met thermisch isolerend materiaal

ES NOTA: Aparatos no aptos para ser cubiertos de material térmicamente aislante

DA N.B.: Armaturerne må ikke dækkes af varmeisolerende materiale.

NO N.B.: Apparatene passer ikke til å dekkes av termoisolerende materialer.

SV OBS! Utrustningen får inte täckas över med värmeisolerande material

RU Внимание: Приборы непригодны для покрытия термоизоляционным материалом.

ZH 灯具不适宜用隔热材料加以覆盖。

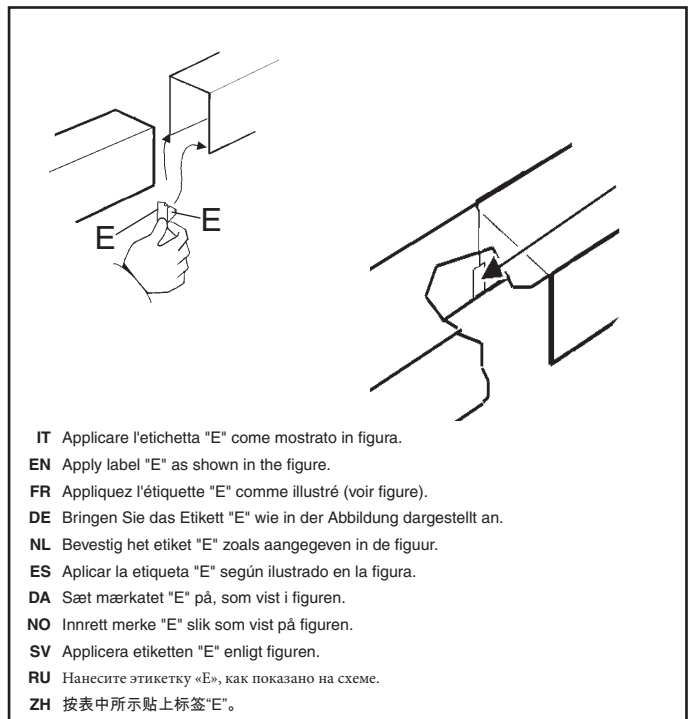
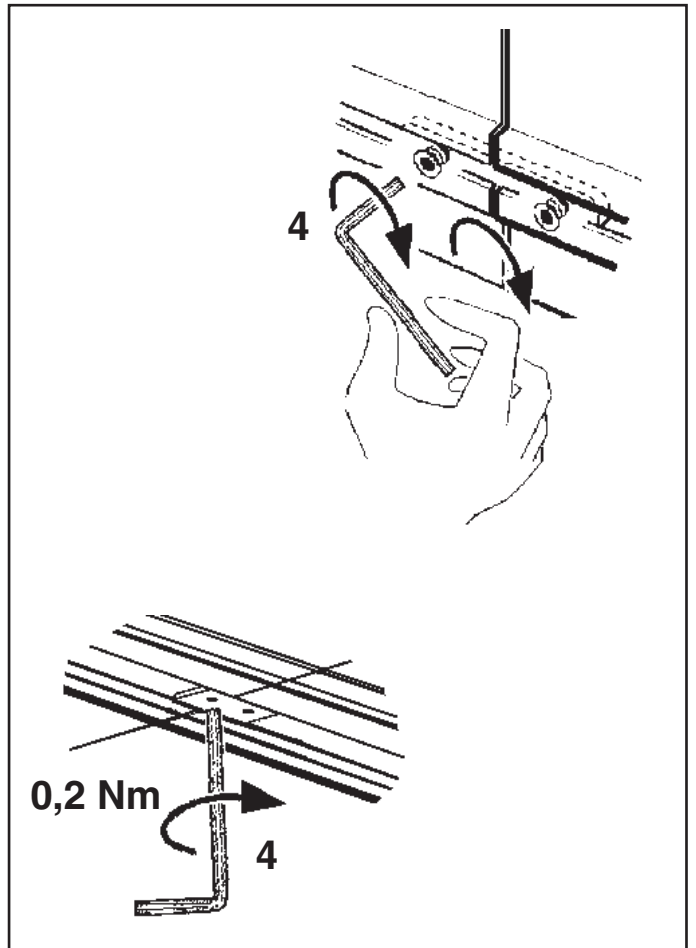
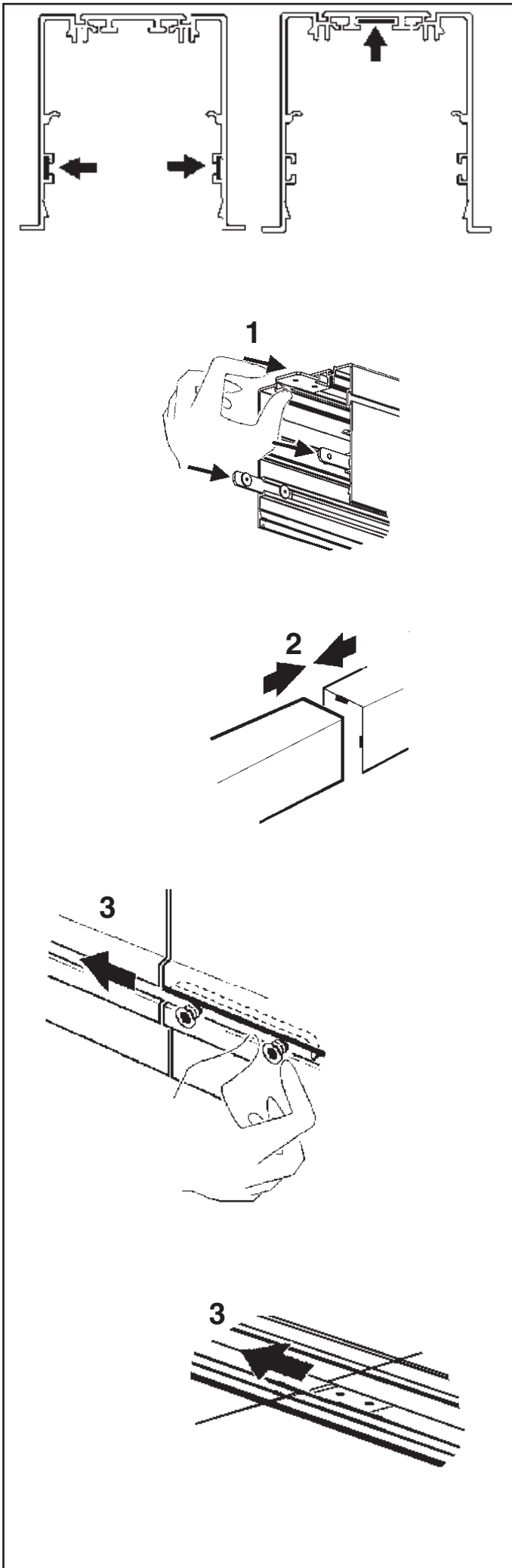

- IT Applicare l'etichetta "E" come mostrato in figura.
- EN Apply label "E" as shown in the figure.
- FR Appliquez l'étiquette "E" comme illustré (voir figure).
- DE Bringen Sie das Etikett "E" wie in der Abbildung dargestellt an.
- NL Bevestig het etiket "E" zoals aangegeven in de figuur.
- ES Aplicar la etiqueta "E" según ilustrado en la figura.
- DA Sæt mærkatet "E" på, som vist i figuren.
- NO Innrett merke "E" slik som vist på figuren.
- SV Applicera etiketten "E" enligt figuren.
- RU Нанесите этикетку «E», как показано на схеме.
- ZH 按表中所示贴上标签“E”。

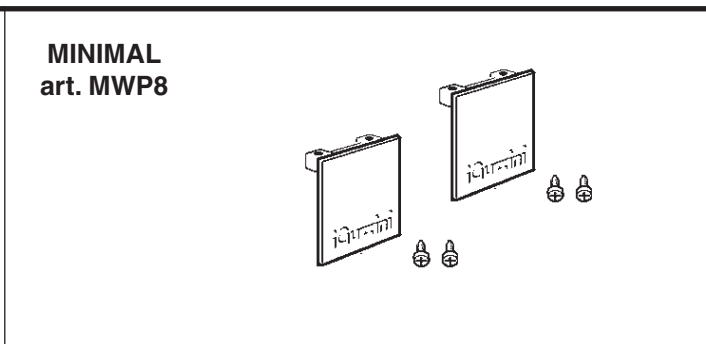
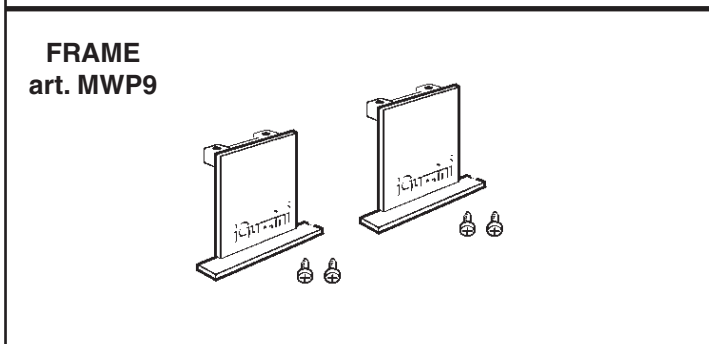
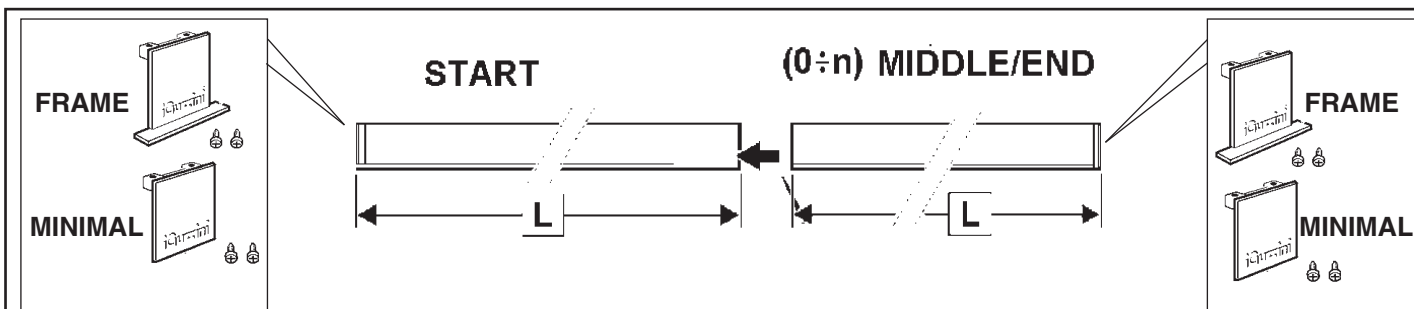

UP/ DOWN

TYPE	L (mm)	 ART.	START	MIDDLE/END		
 GENERAL LIGHTING LOW CONTRAST	1208	Q368	●			Q416 - Q417 - Q418 - Q419
	2397	Q369	●		2x	Q416 - Q417 - Q418 - Q419
	3596	Q370	●			QH89 - QH90 - QH91 - QH92
	3596	Q371			●	QH89 - QH90 - QH91 - QH92
 UGR <19°	1208	Q432	●			Q456 - Q457 - Q458 - Q459
	2397	Q433	●		2x	Q456 - Q457 - Q458 - Q459
	3596	Q434	●			QH97 - QH98 - QH99 - QI00
	3596	Q435			●	QH97 - QH98 - QH99 - QI00

DOWN

TYPE	L (mm)	 ART.	START	MIDDLE/END		
 GENERAL LIGHTING LOW CONTRAST	612	Q356 - Q362 - R401 - R407	●			Q404 - Q407 - Q410 - Q413
	898	Q360 - Q366 - R405 - R411			●	Q405 - Q408 - Q411 - Q414
	1208	Q357 - Q363 - R402 - R408	●			Q406 - Q409 - Q412 - Q415
	2397	Q358 - Q364 - R403 - R409	●		2x	Q406 - Q409 - Q412 - Q415
	3596	Q359 - Q365 - R404 - R410	●			QH85 - QH86 - QH87 - QH88
	3596	Q361 - Q367 - R406 - R412			●	QH85 - QH86 - QH87 - QH88
 UGR <19°	612	Q420 - Q426 - R421 - R427	●			Q444 - Q447 - Q450 - Q453
	898	Q424 - Q430 - R425 - R431			●	Q445 - Q448 - Q451 - Q454
	1208	Q421 - Q427 - R422 - R428	●			Q446 - Q449 - Q452 - Q455
	2397	Q422 - Q428 - R423 - R429	●		2x	Q446 - Q449 - Q452 - Q455
	3596	Q423 - Q429 - R424 - R430	●			QH93 - QH94 - QH95 - QH96
	3596	Q425 - Q431 - R426 - R432			●	QH93 - QH94 - QH95 - QH96

EXAMPLES:

ALIMENTAZIONE
POWER SUPPLY
ALIMENTATION
EINSPEISUNG
STROOMVERZORGING
ALIMENTACION
STRØMFORSYNING
STRØMFORSYNING
STRØMFORSYNING
ELFØRSØRJNING
ЭЛЕКТРОПИТАНИЕ
电源

ALIMENTAZIONE
POWER SUPPLY
ALIMENTATION
EINSPEISUNG
STROOMVERZORGING
ALIMENTACION
STRØMFORSYNING
STRØMFORSYNING
STRØMFORSYNING
ELFØRSØRJNING
ЭЛЕКТРОПИТАНИЕ
电源

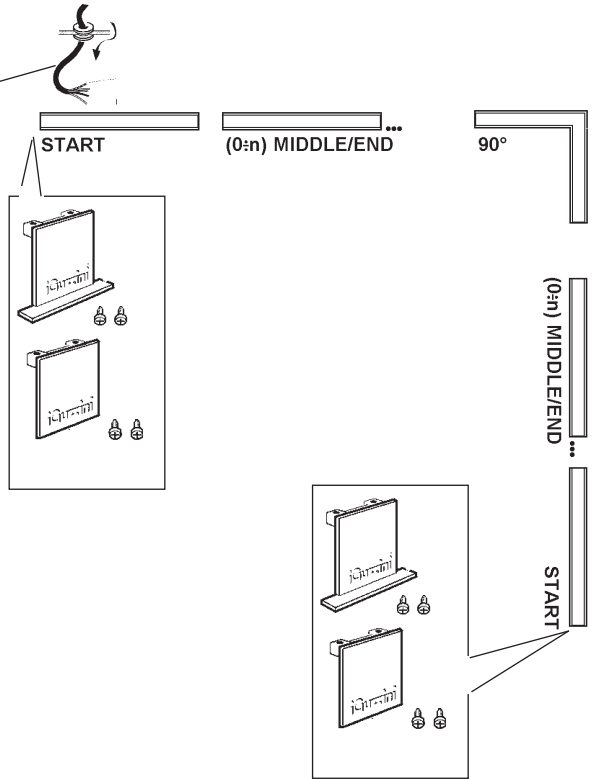
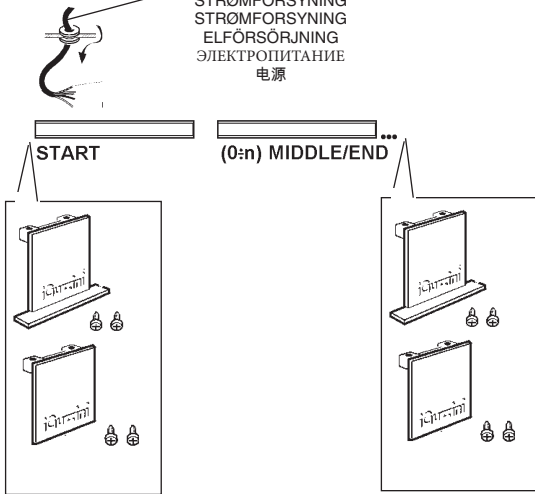

ALIMENTAZIONE
POWER SUPPLY
ALIMENTATION
EINSPEISUNG
STROOMVERZORGING
ALIMENTACION
STRØMFORSYNING
STRØMFORSYNING
STRØMFORSYNING
ELFØRSØRJNING
ЭЛЕКТРОПИТАНИЕ
电源

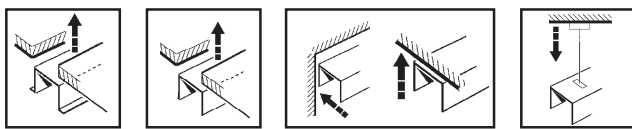
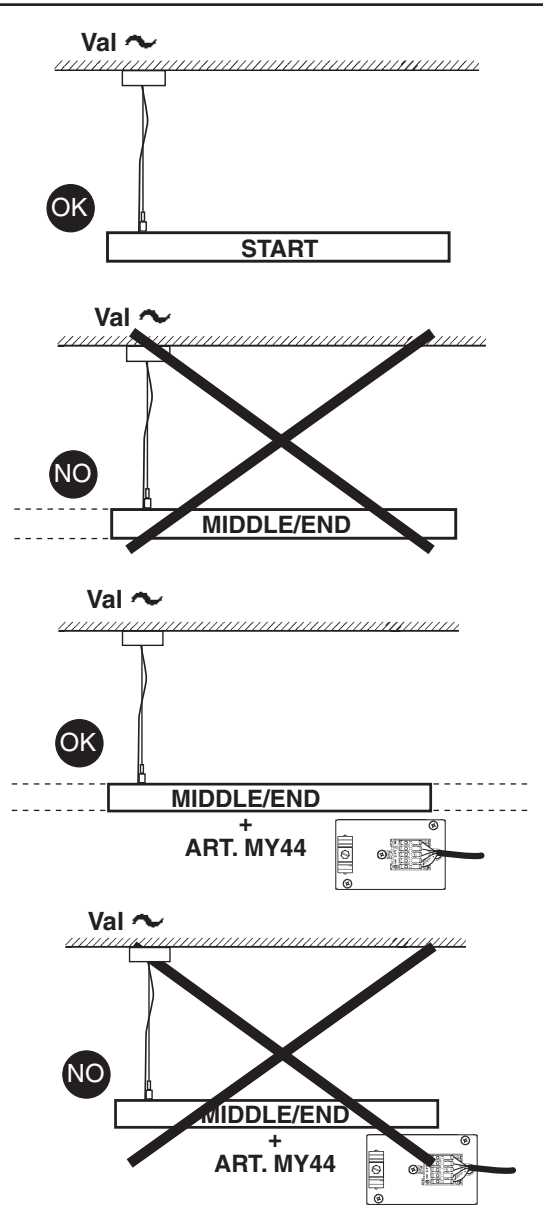
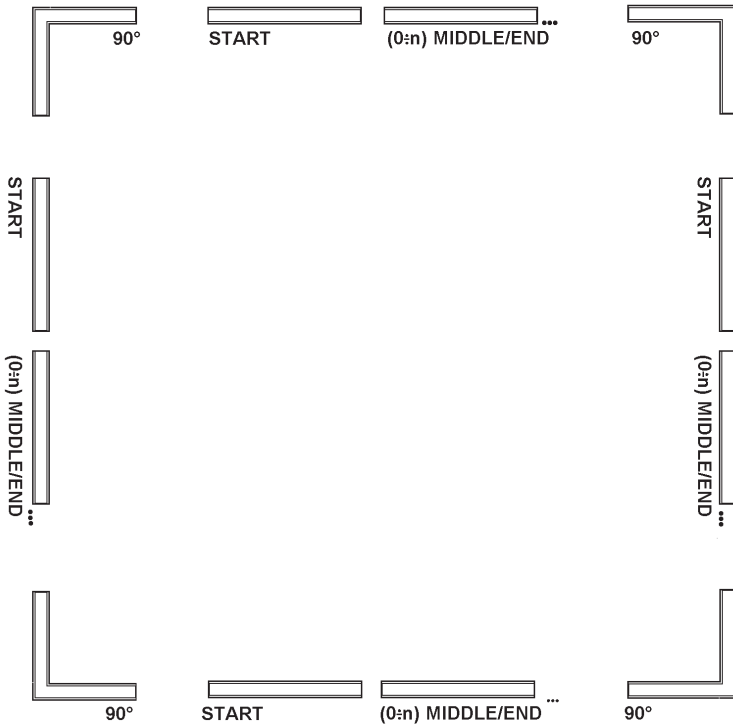



IT DETERMINAZIONE DELLE CORRENTI MASSIME AMMISSIBILI
EN DETERMINING THE MAXIMUM PERMITTED CURRENT
FR DETERMINATION DES COURANTS MAXIMAUX ADMISSIBLES
DE BESTIMMUNG DER ZULÄSSIGEN HÖCHSTSTRÖME
NL VASTSTELLEN VAN DE MAXIMAAL TOEGESTANE STROOMTOEVOER
ES DETERMINACIÓN DE LAS CORRIENTES MÁXIMAS PERMITIDAS
DA BESTEMMELSE AF MAKS. TILLADT STRØMSTYRKE
NO BESTEMME MAKSIMAL TILLATT STRØM
SV FASTSTÄLLANDE MAX. TILLÅTEN STRÖM
RU ОПРЕДЕЛЕНИЕ МАКСИМАЛЬНО ДОПУСТИМОГО ТОКА
ZH 确定最大通过电流

IT Nella progettazione dell'impianto illuminotecnico ed elettrico, determinare le correnti massime ammissibili, considerando i seguenti fattori:
 - 9A corrente nominale ammessa dai morsetti
 - coefficiente di sicurezza per tenere conto delle sovratensioni e contemporaneità;
 - corrente nominale assorbita dai singoli moduli (vedi tabella)

EN When planning the lighting and electrical system, determine the maximum permitted current, taking into account the following factors:
 - 9A the nominal current permitted by terminal block
 - safety coefficient to allow for excess voltage and contemporaneity
 - the nominal current absorbed by single modules (see table)

FR Lors de l'étude de projet de l'installation d'éclairage et de l'installation électrique, déterminer les courants maximaux admissibles en tenant compte des facteurs suivants :
 - 9A courant maximal admis par le bornier
 - coefficient de sécurité tenant compte des surtensions et de la simultanéité;
 - courant nominal absorbé par les différents modules (voir tableau)

DE Bei der Planung einer Beleuchtungs- und Elektroanlage bestimmen Sie die zulässigen Höchstströme unter Berücksichtigung folgender Faktoren:
 - 9A von den Klemmleiste zugelassener Nennstrom
 - Sicherheitskoeffizient zur Einbeziehung von Überspannung und Gleichzeitigkeit;
 - von den einzelnen Modulen aufgenommener Nennstrom (siehe Tabelle)

NL Bij het ontwerpen van de verlichtingstechnische en elektrische installatie moet u de maximaal toegestane stroomtoevoer vaststellen door rekening te houden met de volgende factoren:
 - 9A nominale stroom toegestaan op klemmenstroken
 - veiligheidscoëfficiënt om rekening te houden met overspanning en gelijktijdigheid;
 - nominale opgenomen stroom van de enkele modules (zie tabel)

ES Durante la proyectación de la instalación luminotécnica y eléctrica, determinar las corrientes máximas permitidas, en consideración de los factores siguientes:
 - 9A corriente nominal permitida de la bornera
 - coeficiente de seguridad para considerar sobretensiones y contemporaneidades
 - corriente nominal absorbida por los módulos individuales (ver tabla)

DA I projekteringen af det belysningstekniske og elektriske anlæg, skal man undersøge den maks. tilladte strømstyrke, idet man tager højde for følgende:
 - 9A den nominelle, tilladte strømstyrke fra klæmkerne
 - sikkerhedsfaktor for at sikre mod overspænding og samtidighedsfaktor
 - absorberet nominel strømstyrke på de enkelte moduler (se tabellen).

NO Ved planlegging av lys- og elektrisk system, bestem maksimalt tillatt strøm, ta med i betraktningen følgende faktorer:
 - 9A nominell strøm tillatt av terminalblokkene
 - sikkerhetskoeffisiens for å tillate overflødig spenning og aktualitet,
 - nominell strøm absorbert av enkeltmoduler (se tabell)

SV Vid projekteringen av belysningssystemet och det elektriska systemet ska max. tillåten ström fastställas. Ta hänsyn till följande faktorer:
 - 9A Tillåten nominell ström från kopplingsplintarna
 - Säkerhetskoefficient för att ta hänsyn till överspänningar och sammanlagningar.
 - Tillförd nominell ström från enskilda moduler (se tabell).

RU При расчёте светотехнической системы и электропроводки определите максимальный допустимый ток с учетом следующих факторов:
 - 9A номинальный допустимый ток на клеммных колодках
 - коэффициент безопасности для учета перенапряжения и одновременного включения различных приборов;
 - номинальный ток, поглощаемый отдельными модулями (см. таблицу)

ZH 规划照明和电路系统时，确定最大允许电流，并考虑下列因素：
 - 9A 接线排 允许的正常电流
 - 允许超过规定电压和同时性的安全系数；
 - 为单个模块使用的常规电流（见表）

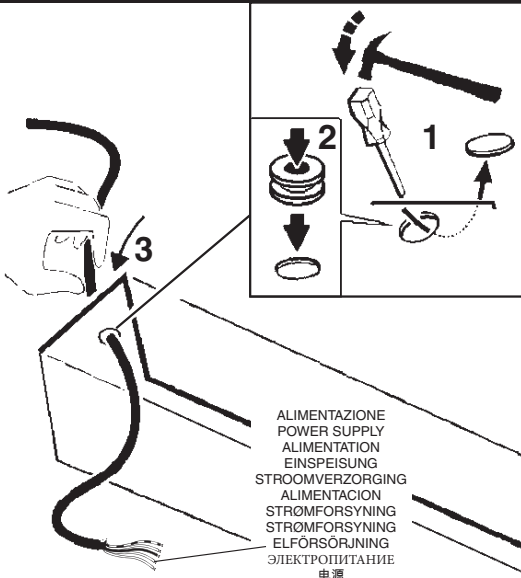

+ art. MY44

IT Utilizzare l'art. MY44 ogni qual volta è necessario effettuare una nuova calata di alimentazione. (vedere tabella delle correnti massime ammissibili.)

EN Use item MY44 whenever it is necessary to effect a new power extension. (see maximum tolerable currents table)

FR Utiliser l'art. MY44 chaque fois qu'il faut réaliser une nouvelle arrivée d'alimentation (voir le tableau des courants maximaux admissibles).

DE Für jede neue Aufhängung zur Stromversorgung muss der Art. MY44 verwendet werden. (siehe Tabelle der zulässigen Höchstströme.)

NL Gebruik het art. MY44 elke keer dat het noodzakelijk is een nieuwe directe bekabeling uit te voeren vanaf het lichtnet. (zie tabel van de maximaal toegestane stroom.)

ES Utilizar el art. MY44 cada vez que se necesita efectuar una nueva alimentación intermedia. (véase tabla de las corrientes máximas permitidas)

DA Anvend art. MY44, når det er nødvendigt at udføre et nyt forsyningsfald (se tabel over maksimalt tilladte strøm).

NO Bruk art.MY44 hver gang du trenger å redusere strømtilførselen igjen (se tabellen for maks. tillatt strømstyrke).

SV Använd art. MY44 varje gång som det är nödvändigt att utföra en ny nätanlutning. (se tabellen för tillåten maximiström.)

RU Использовать арт. MY44 для каждого независимого подвода питания (см. таблицу максимально допустимого тока).

ZH 每次执行新的电源下降时使用零件MY44（参见最大允许电流表格）。

45mm ÷ 50mm art. MY44

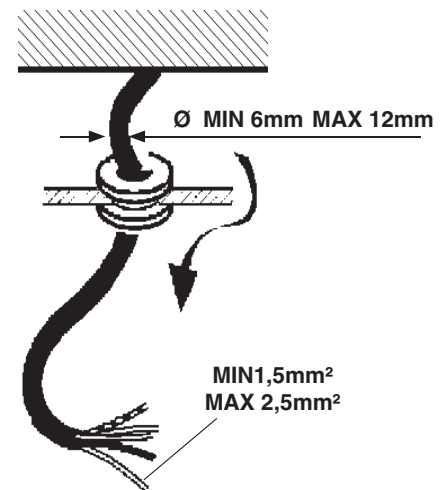
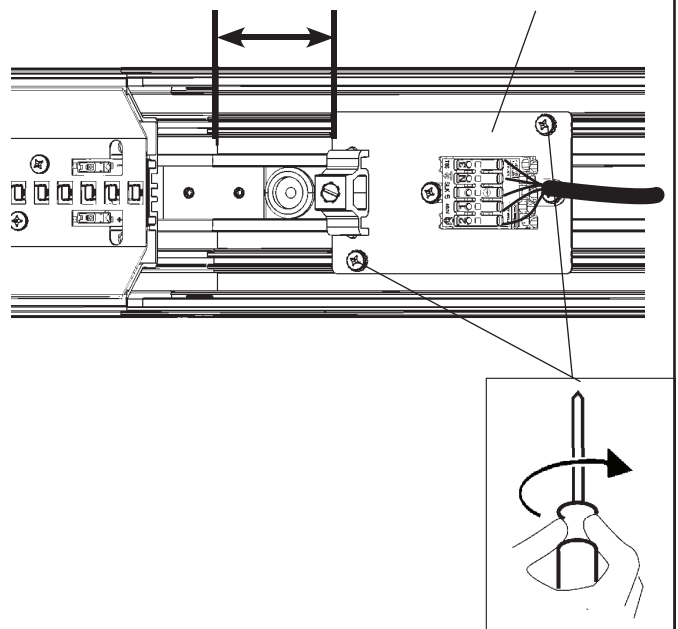

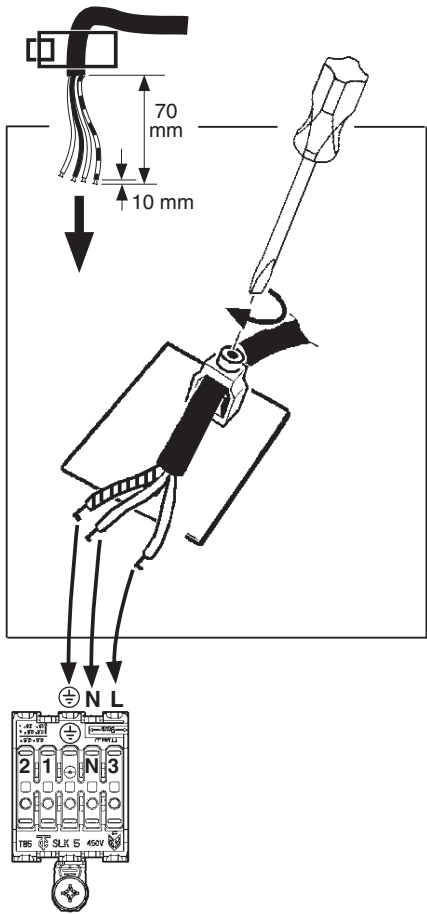

DALI

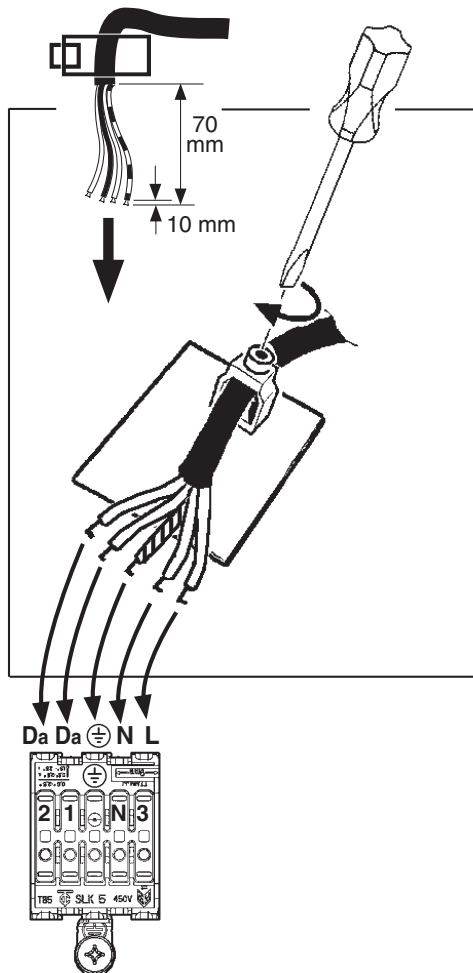

+ art. MWB4

art. MWB4

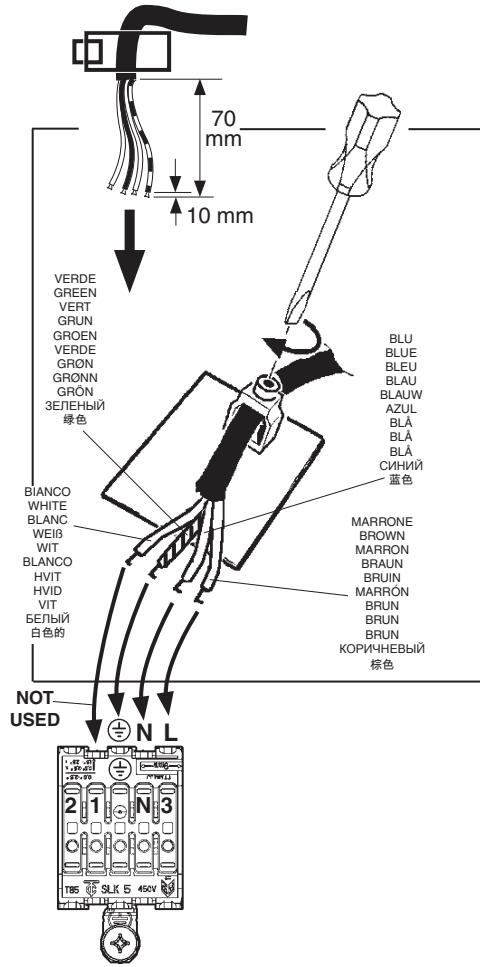

DALI

+ art. MWM2

art. MWM2

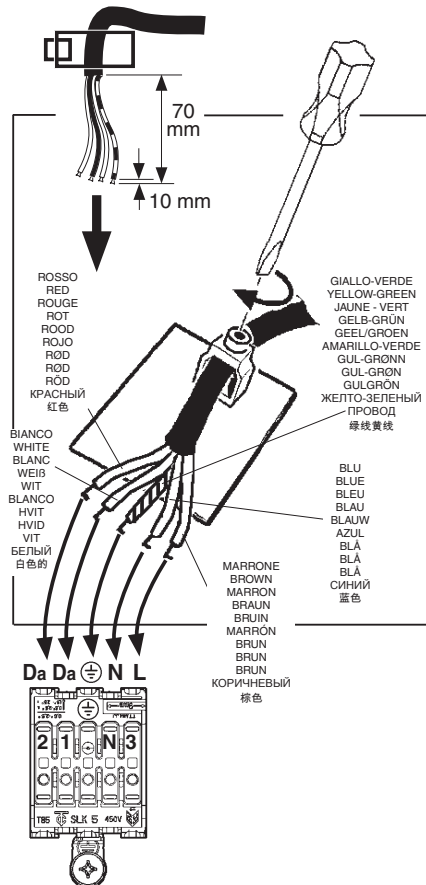

CARICO DALI / DALI LOAD CHARGE DALI (COURANT MAXI ADMISSIBLE) DALI-LAST DALI VERMOGEN CARGA DALI DALI STRØMSTYRKE BELASTNING FOR "DALI" DALI-BELASTNING МАКС. ТОК СИСТЕМЫ DALI С РЕГУЛЯЦИЕЙ ИНТЕНСИВНОСТИ СВЕТА DALI 智能调光系统计算机指定控制参数	INDIRIZZI DALI DALI ADDRESSES ADRESSES DALI DALI-ADRESSEN DALI ADRESSEN DIRECCIONES DALI DALI ADDRESSER ADDRESSER TIL "DALI" DALI-ADDRESSER ЛОГИЧЕСКИЕ АДРЕСА СИСТЕМЫ DALI DALI智能调光系统计算机指定控制参数
1 (2 mA)	1
ART. QH86 - QH88 - QH90 - QH92 2(4 mA)	2

TOUCH DIM

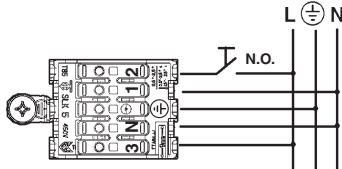

- IT** I dispositivi con cablaggio digitale possono essere dimmerati con dispositivi DALI o con pulsante normalmente aperto (N.O.) da collegare come da schema.
- EN** Devices with digital control gear may be dimmed using DALI devices or a normally-open button (N.O.) to be connected as shown in the diagram.
- FR** Les articles à câblage numérique peuvent fonctionner avec des variateurs à dispositifs DALI ou à bouton poussoir normalement ouvert (N.O.) à relier conformément au schéma.
- DE** Die Geräte mit digitaler Verkabelung können mit Hilfe von DALI-Vorrichtungen oder mit Hilfe eines gemäß Schaltplan anzuschließenden Schließers (N.O.) gedimmt werden.
- NL** De producten met digitale bekabeling kunnen worden gedimd met DALI systemen of met een N.O. (normally open) knop, die moet worden aangesloten volgens schema.
- ES** Los dispositivos con cableado digital pueden regularse con dispositivos DALI o con un interruptor de botón normalmente abierto (N.O.) que se conecta según ilustrado en el esquema.
- DA** Produkter med digital kabelføring kan dæmpes med DALI-anordninger eller med kontakten, som normalt er åben (N.O.) og som skal tilsluttes, som vist.
- NO** Produkter med digitalkabler kan dimmes med DALI-anordninger eller med en normalt åpen (NO) trykkbryter som kobles som vist i koblingskjema.
- SV** Produkter med digital kabeldragning kan förses med dimmer. Detta kan göras med DALI-anordningarna eller med en normalt öppen kontakt (N.O.) som ska anslutas enligt schemat.
- RU** Интенсивность приборов с цифровой проводкой может регулироваться посредством устройств DALI или нормально разомкнутой кнопкой (Н.Р.), подключаемой согласно схеме.
- ZH** 带有数字控制装置的设备可以通过 DALI (数字化可寻址调光接口) 设备或者一个连接方式如图中所示的常开按钮 (N.O.) 进行亮度调节

- IT** Pilotare diversi prodotti DALI tramite pulsante (es: Touch-dim, Switch-dim, Push-dim, Direct-dim, etc.) potrebbe causare dei problemi di sincronizzazione tra gli stessi. È possibile ovviare a questo problema dotandosi di dispositivi aggiuntivi. Per maggiori informazioni vi invitiamo a contattarci direttamente.
- EN** Controlling different DALI products through buttons (e.g.: Touch-dim, Switch-dim, Push-dim, Direct-dim, etc.) may lead to product synchronisation problems. This problem can be overcome by using additional devices. For further information, please contact us directly.
- FR** Piloter plusieurs produits DALI par bouton (ex : Touch-dim, Switch-dim, Push-dim, Direct-dim, etc.) pourrait causer des problèmes de synchronisation entre eux. Ce problème peut être évité en s'équipant de dispositifs supplémentaires. Pour de plus amples renseignements, veuillez nous contacter directement.
- DE** Die Steuerung verschiedener DALI-Produkte mittels Taste (z.B.: Touch-dim, Switch-dim, Push-dim, Direct-dim etc.) kann eventuell zu Synchronisierungsproblemen zwischen diesen führen. Dieses Problem lässt sich durch den Einsatz von zusätzlichen Geräten beheben. Wenn Sie weitere Informationen wünschen, setzen Sie sich bitte direkt mit uns in Verbindung.
- NL** Het besturen van verschillende DALI producten m.b.v. dezelfde knop (bv.: Touch-dim, Switch-dim, Push-dim, Direct-dim, etc.) kan synchronisatieproblemen tussen de producten opleveren. Men kan dit probleem voorkomen door extra systemen aan te sluiten. Voor verdere informatie raden we u aan direct contact met ons op te nemen.
- ES** El mando de varios productos DALI por tecla (ej: Touch-dim, Switch-dim, Push-dim, Direct-dim, etc.) podría causar problemas de sincronización entre ellos. Es posible prevenir este problema utilizando dispositivos adicionales. Para más información, contacte directamente con nosotros.
- DA** Hvis DALI-produkterne styres ved hjælp af knapperne (fx. Touch-dim, Switch-dim, Push-dim, Direct-dim osv.), kan det skabe problemer med synkronisering af samme. Dette problem kan undgås, hvis man køber ekstra enheder. For yderligere oplysninger, kontakt os direkte.
- NO** Å styre ulike DALI-produkter ved hjelp av en trykknappbryter (f.eks. touch-dim, switch-dim, push-dim, direct-dim, osv.) vil kunne føre til problemer med synkronisering mellom dem. Dette problemet kan løses ved hjelp av noen tilleggsinnretninger. Ta gjerne kontakt med oss for mer informasjon om dette.
- SV** Styring av olika DALI-produkter med knapp (t.ex.: Touch-dim, Switch-dim, Push-dim, Direct-dim o.s.v.) kan orsaka synkroniseringsproblem mellan dessa. Detta problem kan åtgärdas med tilläggsanordningar. För mer information kan du kontakta oss direkt.
- RU** Управление различными продуктами DALI с помощью кнопки (напр.: Touch-dim, Switch-dim, Push-dim, Direct-dim и пр.) может вызвать проблемы синхронизации между ними. Эту проблему можно устранить путем задействования дополнительных устройств. За получением более подробной информации просим Вас связаться с нами непосредственно.
- ZH** 通过按钮控制不同的 DALI 产品 (例如: 触摸调光、切换调光、按压调光、直接调光等) 可能会导致产品的同步问题。该问题可通过使用其他额外的装置加以克服。如需了解更多信息, 请直接与我们联系。

EXAMPLE:



START

START

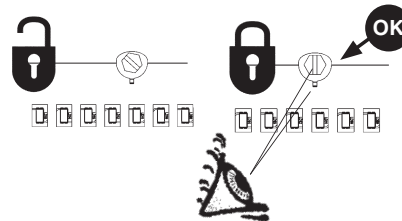
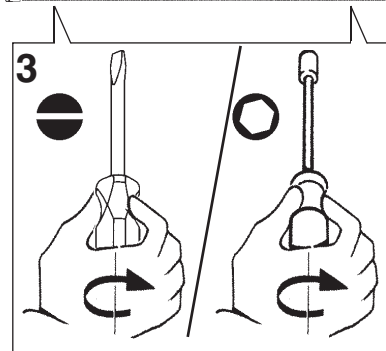
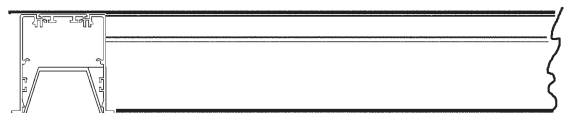
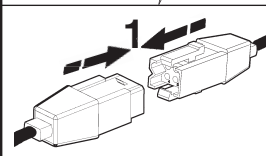
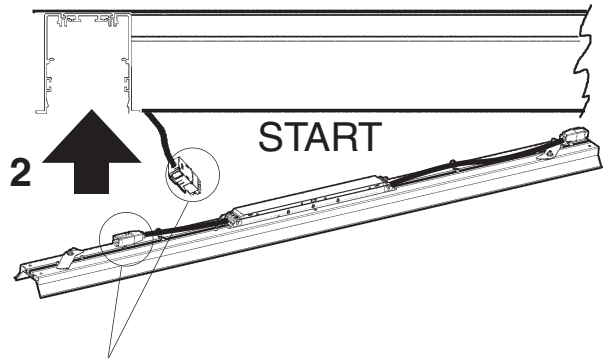

EXAMPLE:



START/ MIDDLE

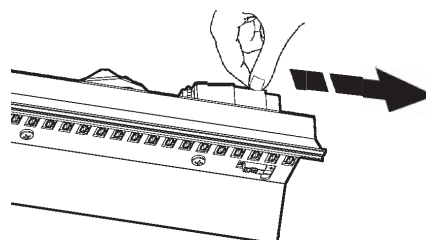

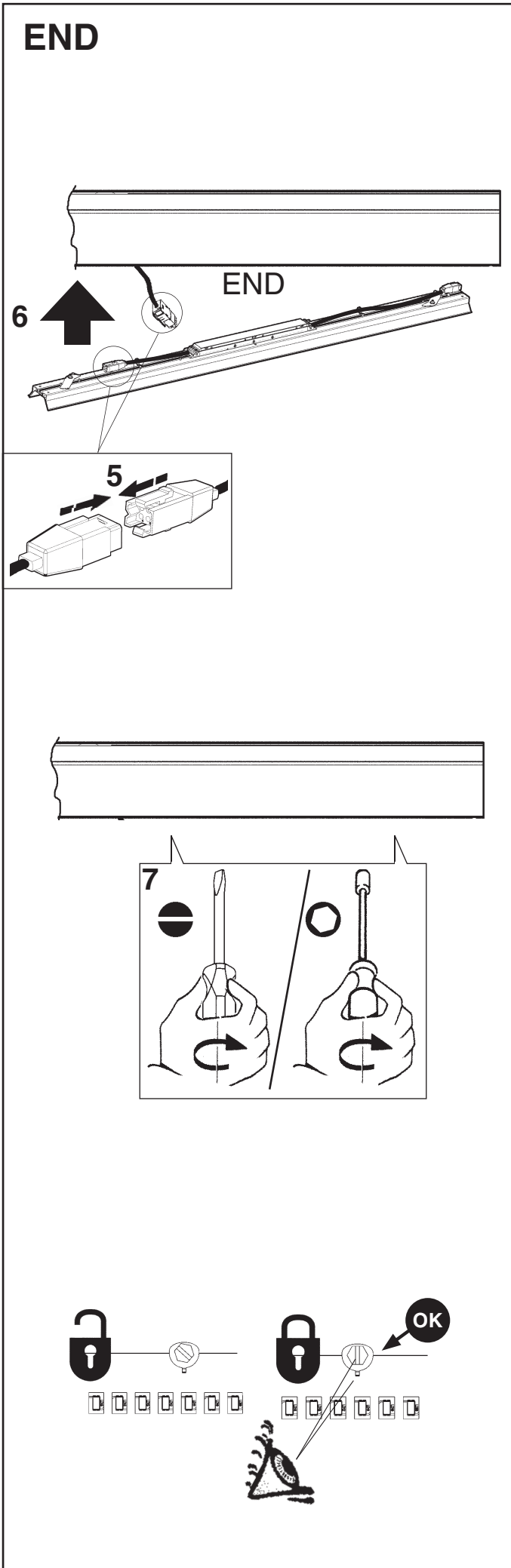
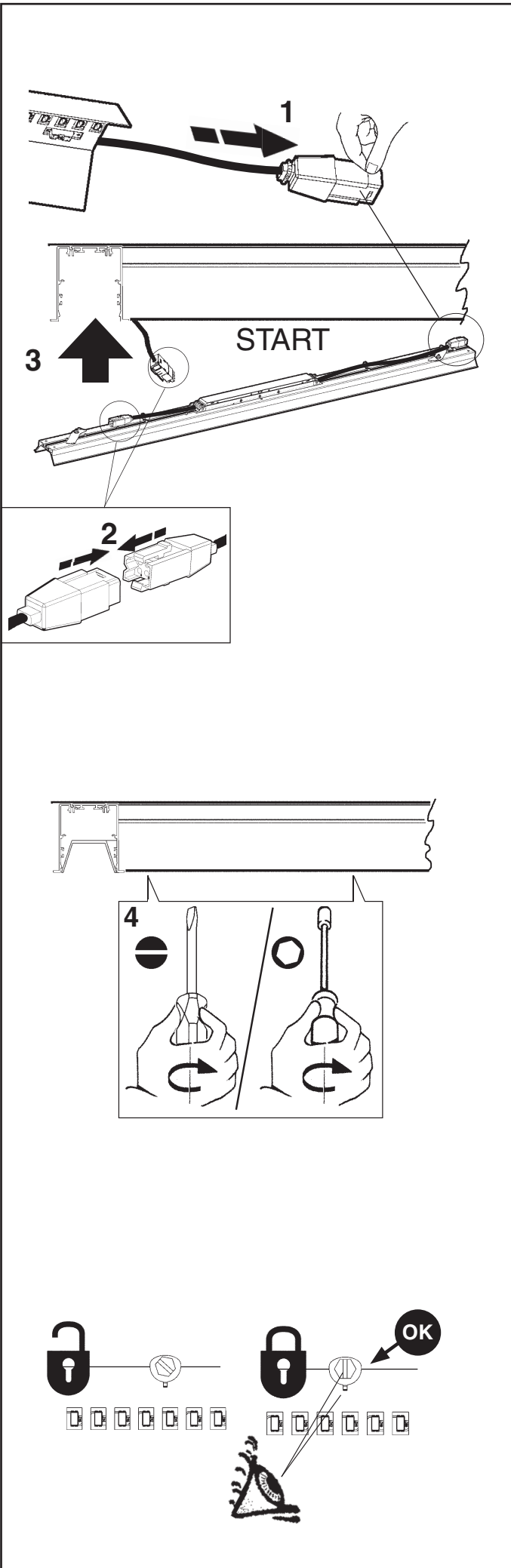

EXAMPLE:

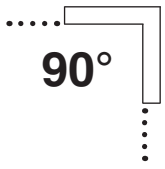

90°

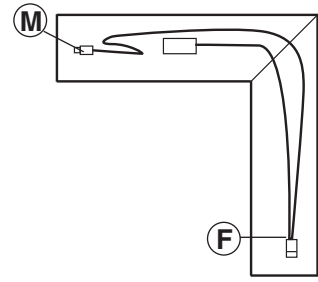
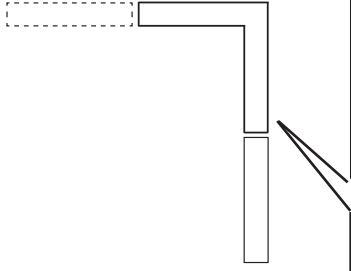

EXAMPLE:

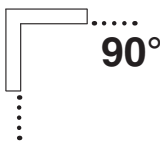

90°

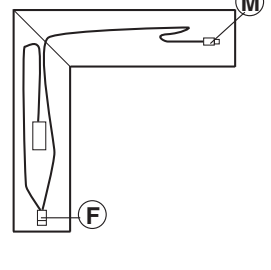
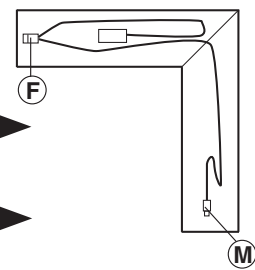
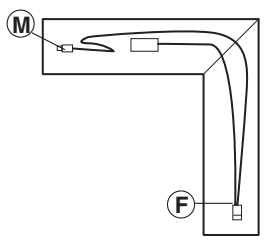
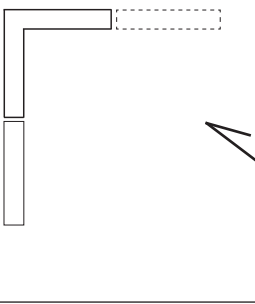

M

Maschio
Male
Male
Stecker
Mannelijk
Macho
HANSTIK
HANN-
HANE
ШТЕПСЕЛЬ
外插头

F

Femina
Female
Femelle
Buchse
Vrouwelijk
Hembra
HUNSTIK
HUNN-
HONA
ШТЕККЕР
内插头

M

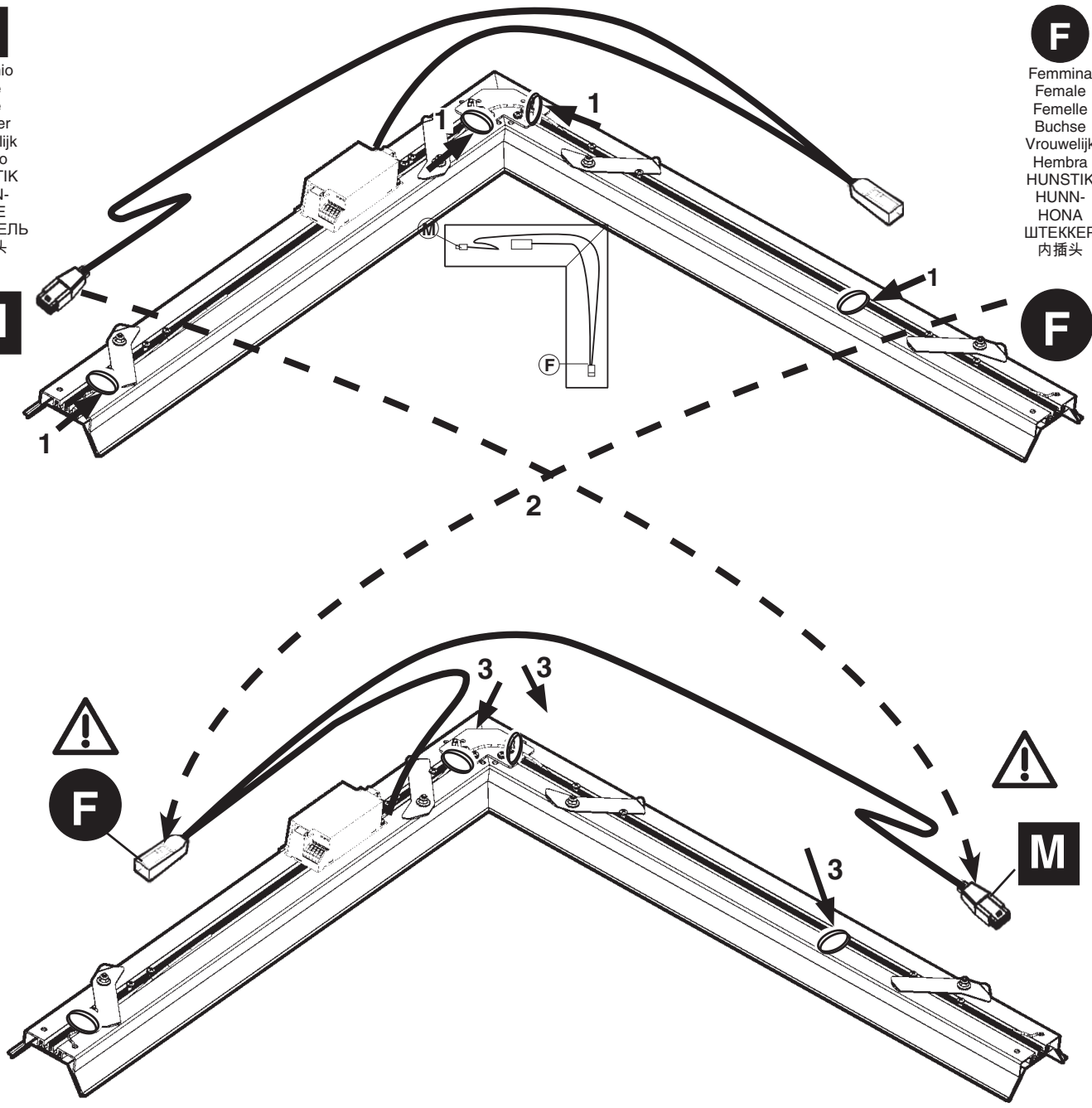

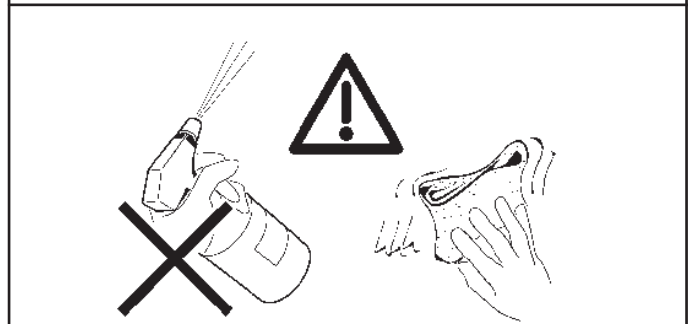
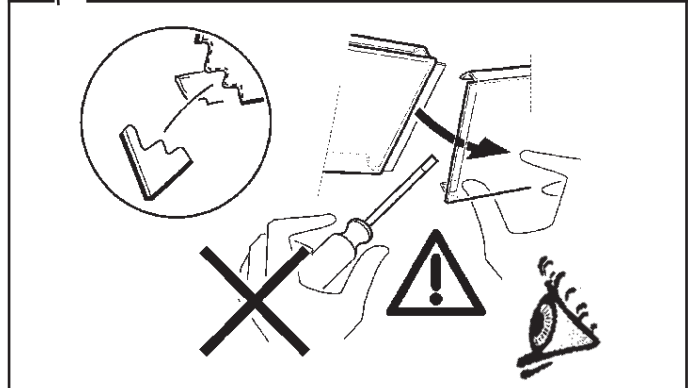
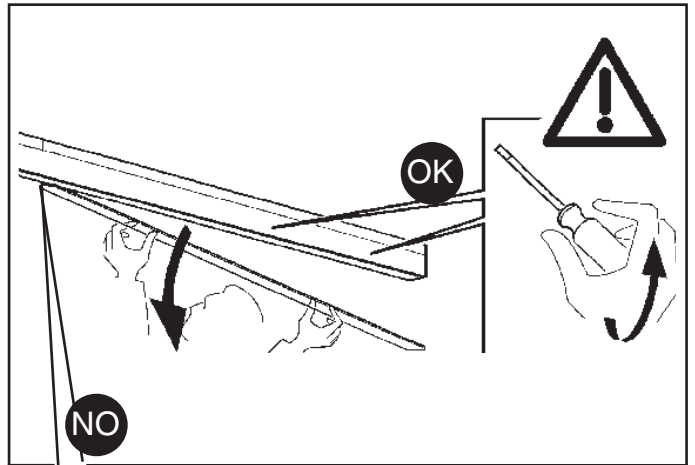
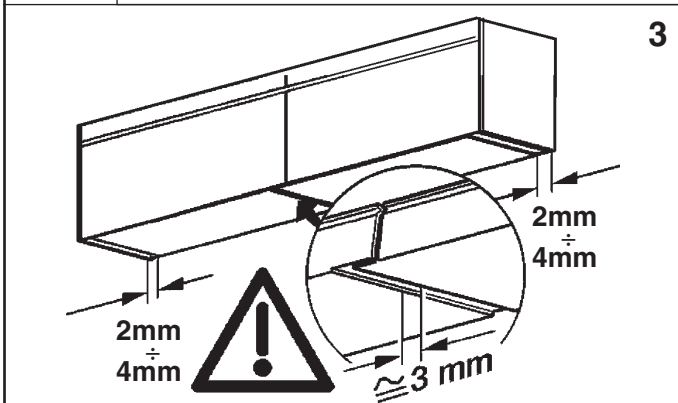
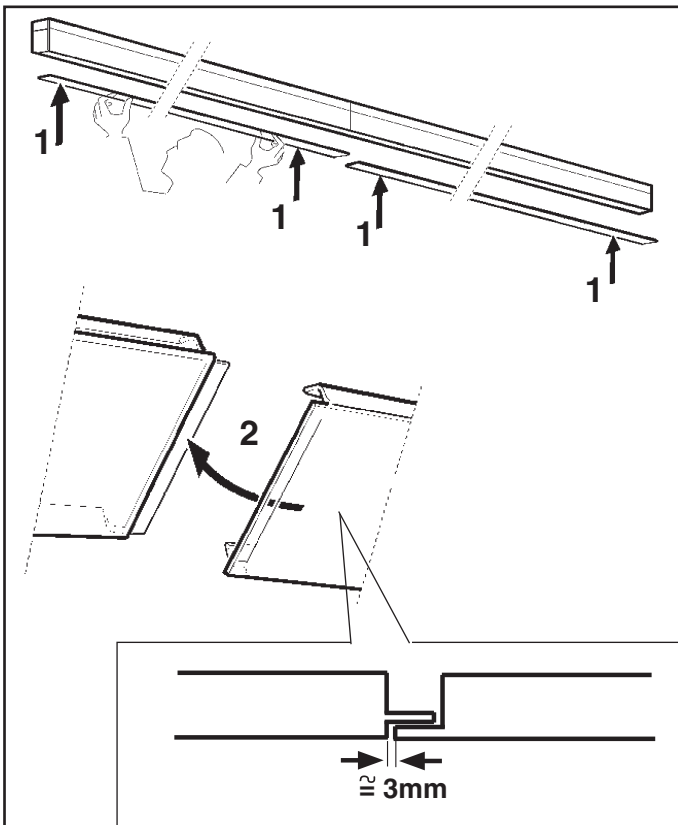
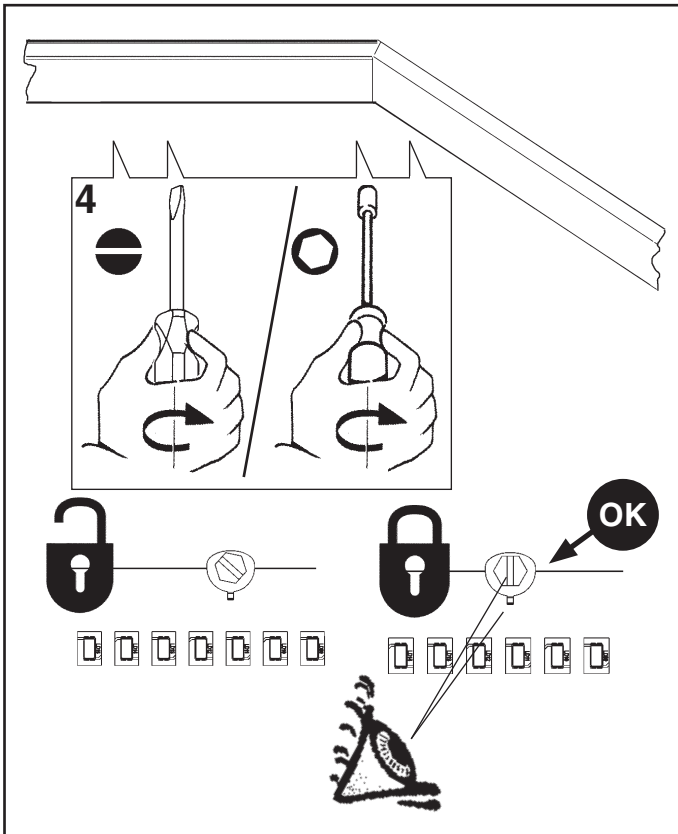

IT N.B.: Per l'eventuale pulizia non utilizzare acqua o solventi vari, usare esclusivamente panni morbidi asciutti.

EN N.B.: When cleaning, do not use water or any type of solvent. Use only soft dry cloths.

FR N.B.: En cas de nettoyage, n'utiliser ni eau ni solvants en général, n'utiliser que des chiffons doux et secs.

DE N.B.: Zur eventuellen Reinigung weder Wasser noch Lösungsmittel, sondern ausschließlich ein weiches, trockenes Tuch verwenden.

NL N.B.: Gebruik voor het schoonmaken geen water of oplosmiddelen, maar uitsluitend zachte stofdoeken.

ES NOTA: Para la limpieza eventual no usar agua ni solventes de cualquier género, sino exclusivamente un pano suave y seco.

DA N.B.: Ved rengøring skal man undgå brug af vand eller forskellige opløsningsmidler. Brug udelukkende en tør, blød klud.

NO N.B.: For en eventuell rengjøring, ikke benytt vann eller ymse løsemidler, bruk kun tørre myke kluter.

SV OBS! Använd inte vatten eller diverse lösningsmedel vid eventuell rengöring. Använd endast mjuka och torra trasor.

RU ПРИМЕЧАНИЕ: При необходимости произвести чистку не используйте воду или различные растворители, а исключительно сухие мягкие тряпки.

ZH 注意：不要用水或任何类型的溶剂进行清洗。只能使用干燥的软布。

IT N.B.: Per la sostituzione dei LED contattare l'azienda iGuzzini.

EN N.B.: For information on LED replacement please contact iGuzzini.

FR N.B.: Pour procéder au remplacement de la LED, adressez-vous à la société iGuzzini.

DE N.B.: Bezüglich des Austausches der LED kontaktieren Sie bitte die Firma iGuzzini.

NL N.B.: Voor het vervangen van de LED neemt u contact op met het bedrijf iGuzzini.

ES NOTA: Para sustituir el LED llame a la empresa iGuzzini.

DA N.B.: For udskiftning af lysdioden, skal man kontakte iGuzzini.

NO N.B.: For informasjon om skifte av LED, vennligst ta kontakt med iGuzzini.

SV OBS! För byte av lysdioden, kontakta företaget iGuzzini.

RU ПРИМЕЧАНИЕ: Для замены СИДов обращайтесь в компанию iGuzzini.

ZH 注意：如需LED更换的信息，请联系iGuzzini。

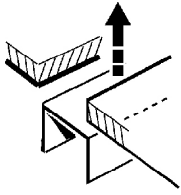

iN90 Led (MINIMAL)

IT Attenzione:

La sicurezza dell'apparecchio e' garantita solo con l'uso appropriato delle seguenti istruzioni; pertanto e' necessario conservarle.

EN Warning:

The safety of this fixture is guaranteed only if you comply with these instructions; remember to conserve in a safe place.

FR Attention:

La sécurité de l'appareil n'est garantie qu'en cas d'utilisation correcte des instructions suivantes; il faut par conséquent les conserver.

DE Achtung:

Die Sicherheit des Gerätes wird nur durch sachgemässe befolgung nachstehender anweisungen gewährleistet; ihre aufbewahrung ist deshalb sehr wichtig.

NL Opgelet:

De veiligheid van dit toestel is slechts dan gegarandeerd als indien de volgende instructies strikt worden toegepast; daarom moet men ze ook bewaren.

ES Atencion:

La seguridad del aparato se garantiza solo cumpliendo cuidadosamente las siguientes instrucciones; por ello, es necesario conservarlas.

DA Bemærk:

Sikkerheden ved brug af armaturet kan kun garanteres, hvis disse anvisninger følges; sørg derfor for at gemme dem.

NO Advarsel:

Sikkerheten til dette apparatet garanteres kun hvis du overholder disse instruksjonene; husk å oppbevare dem på et trygt sted.

SV Observera:

Utrustningens säkerhet kan endast garanteras om dessa anvisningar respekteras i detalj. Spara därför dessa anvisningar för framtida konsultation.

RU Внимание:

Мы гарантируем безопасную эксплуатацию изделия только при соблюдении следующих инструкций; с этой целью необходимо сохранить данную брошюру.

ZH 警告:

为确保该装置安全，请遵守操作指示；并于安全场所放置。

تحذير:

لا يمكن ضمان سلامة هذا الجهاز إلا إذا التزمت بهذه التعليمات. يجب حفظها في مكان آمن.

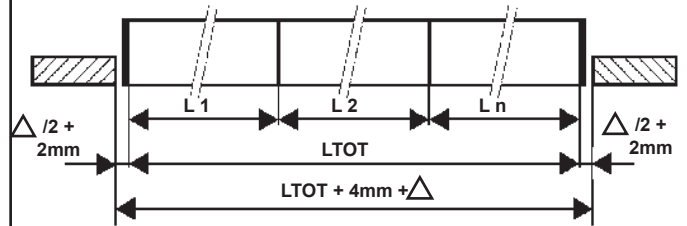
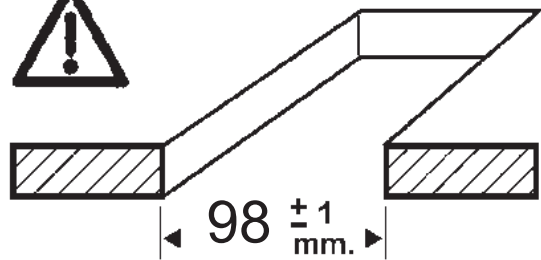
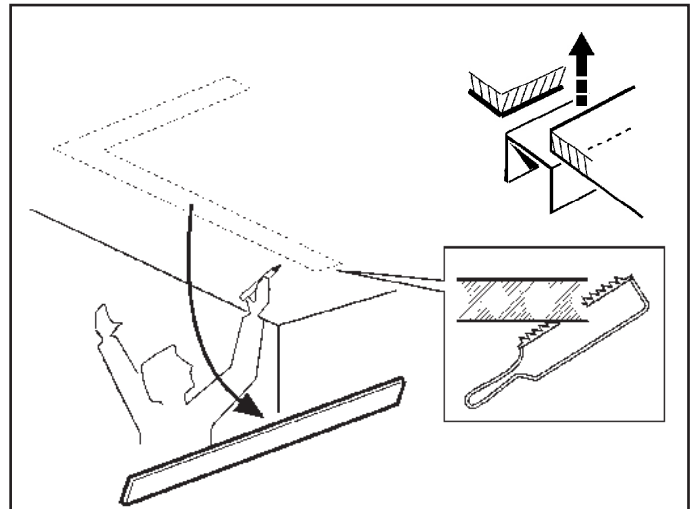
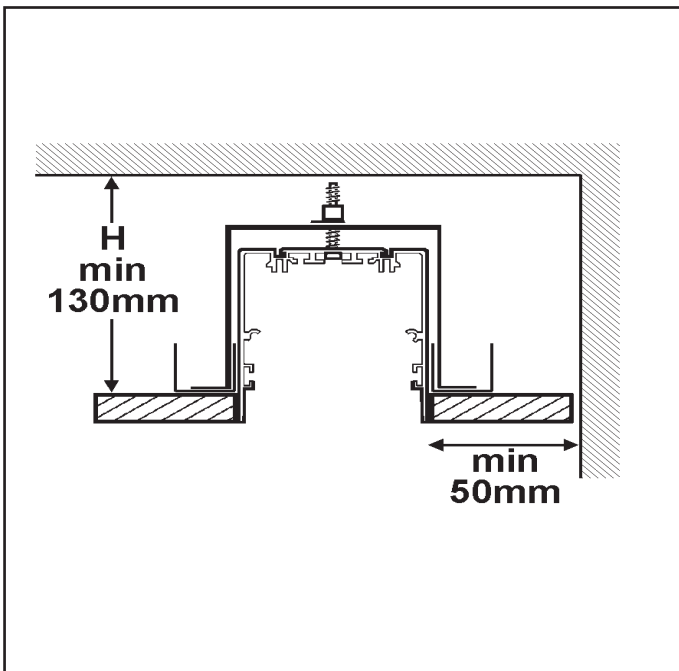

Ltot = MAX 30 mt

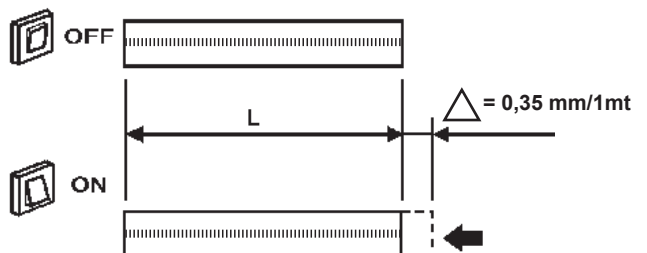

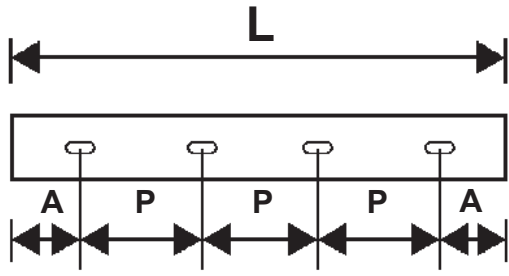

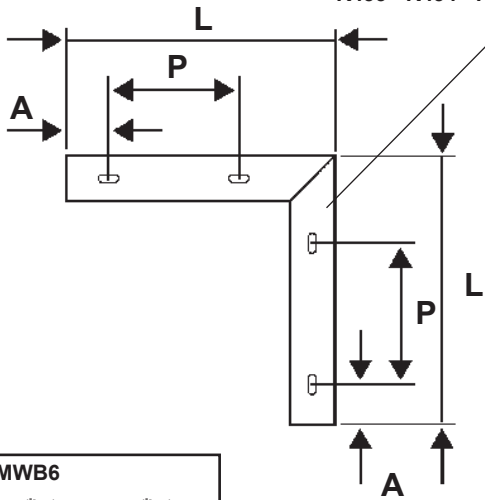

Q392 - Q393 - Q394 - Q395
 Q440 - Q441 - Q442 - Q443
 R413 - R414 - R415 - R416
 R433 - R434 - R435 - R436

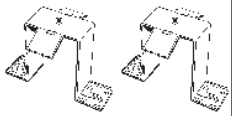

art. MWB6



ART.	L (mm)	P (mm)	A (mm)	
Q362 - Q426 - R401 - R421	612	212	200	2
Q363 - Q368 - Q427 - Q432 R402 - R422	1208	500	354	2
Q364 - Q369 - Q428 - Q433 R403 - R423	2397	800	399	3
Q365 - Q370 - Q429 - Q434 R404 - R424	3596	980	328	4
Q366 - Q430 - R405 - R425	898	498	200	2
Q367 - Q371 - Q431 - Q435 R406 - R426	3596	980	328	4
Q392 - Q393 - Q394 - Q395 Q440 - Q441 - Q442 - Q443 R413 - R414 - R415 - R416 R433 - R434 - R435 - R436	658 x 658	250	200	4

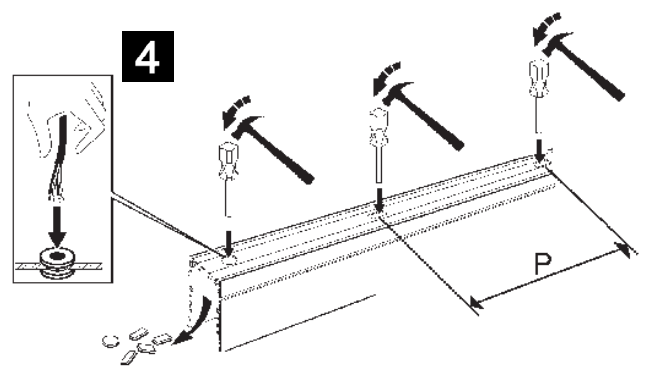
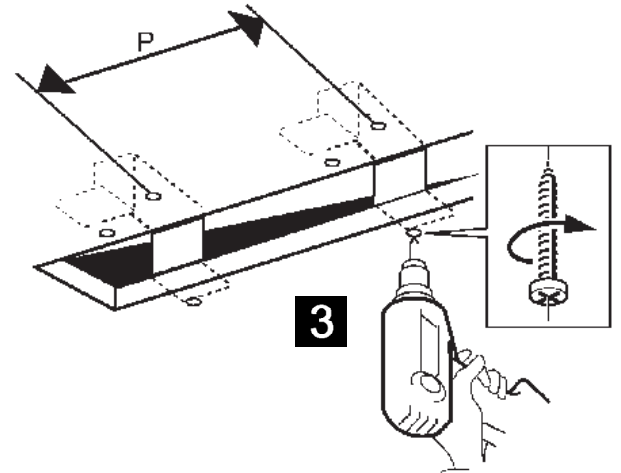
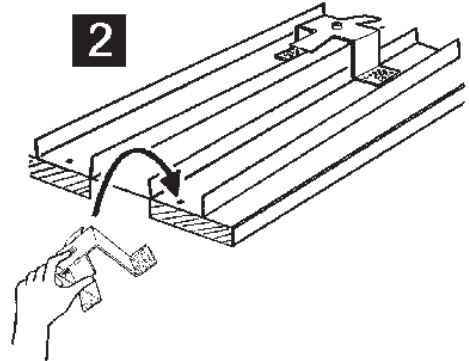
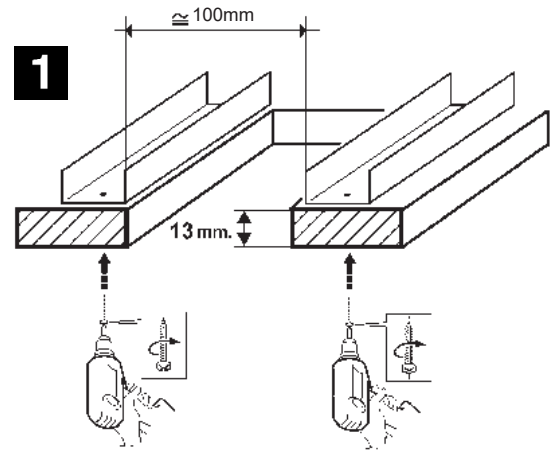

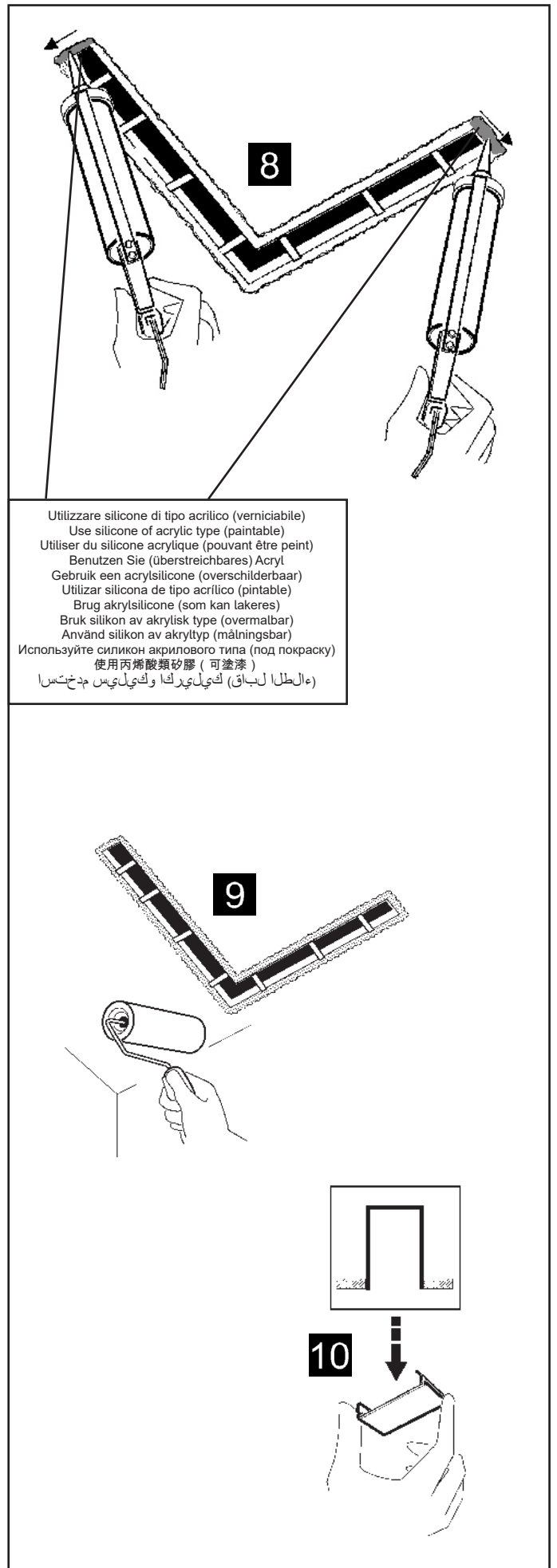
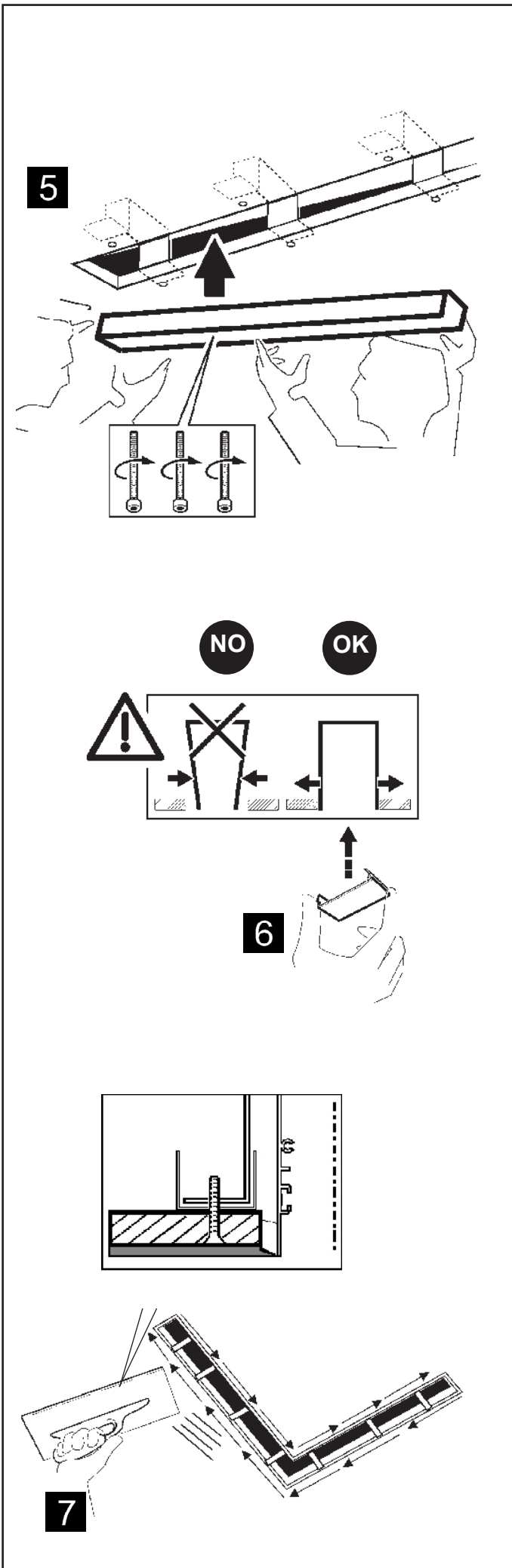

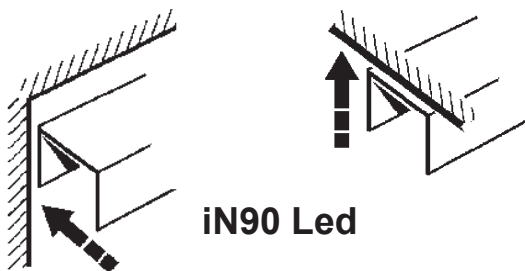

iN90 Led

IT Attenzione:

La sicurezza dell'apparecchio e' garantita solo con l'uso appropriato delle seguenti istruzioni; pertanto e' necessario conservarle.

EN Warning:

The safety of this fixture is guaranteed only if you comply with these instructions; remember to conserve in a safe place.

FR Attention:

La sécurité de l'appareil n'est garantie qu'en cas d'utilisation correcte des instructions suivantes; il faut par conséquent les conserver.

DE Achtung:

Die sicherheit des gerätes wird nur durch sachgemässe befolgung nachstehender anweisungen gewährleistet; ihre aufbewahrung ist deshalb sehr wichtig.

NL Opgelet:

De veiligheid van di atoestel is slechts dan gegarandeerd als indien de volgende instructies strikt worden toegepast: daarom moet men ze ook bewaren.

ES Atencion:

La seguridad del aparato se garantiza solo cumpliendo cuidadosamente las siguientes instrucciones; por ello, es necesario conservarlas.

DA Bemærk:

Sikkerheden ved brug af armaturet kan kun garanteres, hvis disse anvisninger følges; sørg derfor for at gemme dem.

NO Advarsel:

Sikkerheten til dette apparatet garanteres kun hvis du overholder disse instruksjonene; husk å oppbevare dem på et trygt sted.

SV Observera:

Utrustningens säkerhet kan endast garanteras om dessa anvisningar respekteras i detalj. Spara därför dessa anvisningar för framtida konsultation.

RU Внимание:

Мы гарантируем безопасную эксплуатацию изделия только при соблюдении следующих инструкций; с этой целью необходимо сохранить данную брошюру.

ZH 警告:

为确保该装置安全, 请遵守操作指示; 并于安全场所放置。

AR تحذير: لا يمكن ضمان سلامة هذا الجهاز إلا إذا التزمت بهذه التعليمات. يجب حفظها في مكان آمن.



art. Q426 - Q427 - Q428 - Q429
Q430 - Q431 - Q432 - Q433
Q434 - Q435 - R421 - R422
R423 - R424 - R425 - R426

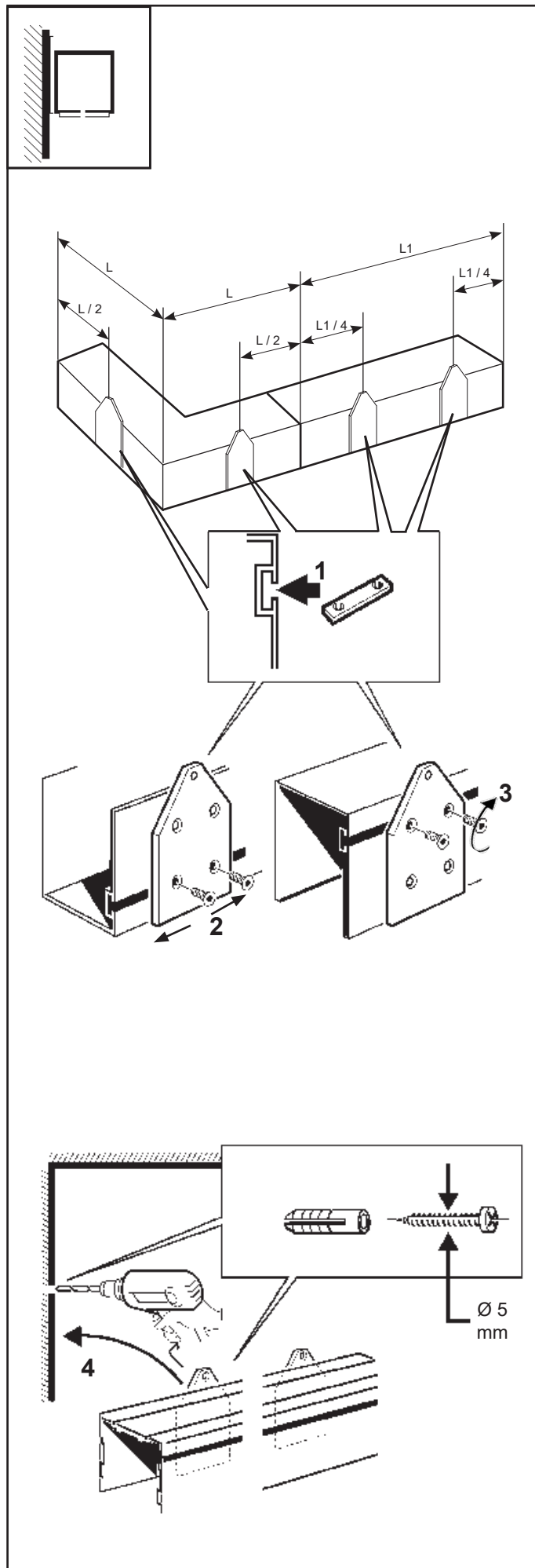

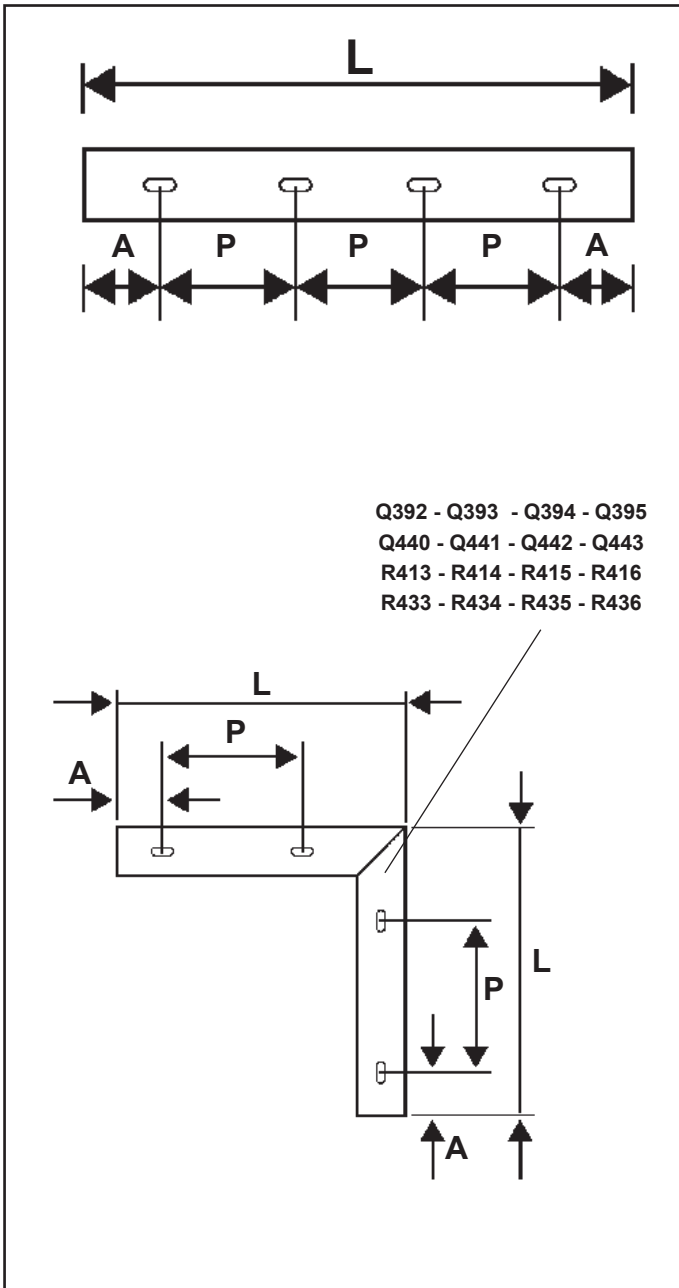
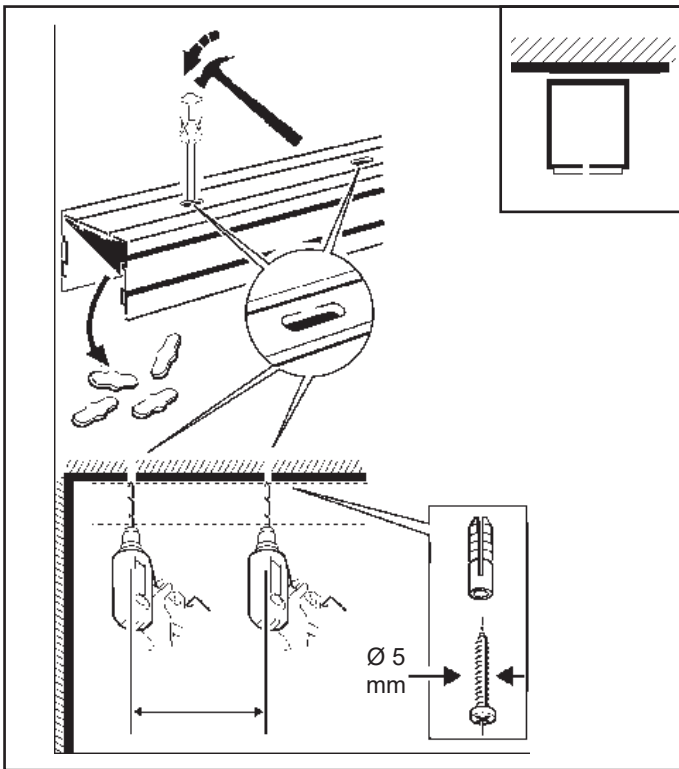

ART.	L (mm)	P (mm)	A (mm)	
Q362 - Q426 - R401 - R421	612	212	200	2
Q363 - Q368 - Q427 - R402 R422	1208	500	354	2
Q364 - Q369 - Q428 - R403 R423	2397	800	399	3
Q365 - Q370 - Q429 - R404 R424	3596	980	328	4
Q366 - Q430 - R405 - R425	898	498	200	2
Q367 - Q371 - Q431 - R406 R426	3596	980	328	4
Q392 - Q393 - Q394 - Q395 Q440 - Q441 - Q442 - Q443 R413 - R414 - R415 - R416 R433 - R434 - R435 - R436	658 x 658	250	200	4



I ATTENZIONE:

LA SICUREZZA DELL'APPARECCHIO E' GARANTITA SOLO CON L'USO APPROPRIATO DELLE SEGUENTI ISTRUZIONI; PERTANTO E' NECESSARIO CONSERVARLE.

GB WARNING:

THE SAFETY OF THIS FIXTURE IS GUARANTEED ONLY IF YOU COMPLY WITH THESE INSTRUCTIONS; REMEMBER TO CONSERVE IN A SAFE PLACE.

F ATTENTION:

LA SECUTIE DE L'APPAREIL N'EST GARANTIE QU'EN CAS D'UTILISATION CORRECTE DES INSTRUCTIONS SUIVANTES; IL FAUT PAR CONSEQUENT LES CONSERVER.

D ACHTUNG:

DIE SICHERHEIT DES GERÄTES WIRD NUR DURCH SACHGEMÄSSE BEFOLGUNG NACHSTEHENDER ANWEISUNGEN GEWÄHRLEISTET; IHRE AUFBEWAHRUNG IST DESHALB SEHR WICHTIG.

NL OPGELET:

DEVEILIGHEID VAN DI ATOESTEL IS SLECHTS DAN GEGARANDEERD ALS INDIEN DE VOLGENDE INSTRUCTIES STRIKT WORDEN TOEGEPAST; DAAROM MOET MEN ZE OOK BEWAAREN.

E ATENCION:

LA SEGURIDAD DEL APARATO SE GARANTIZA SOLO CUMPLIENDO CUIDADOSAMENTE LAS SIGUIENTES INSTRUCCIONES; POR ELLO, ES NECESARIO CONSERVARLAS.

DK BEMÆRK:

SIKKERHEDEN VED BRUG AF ARMATURET KAN KUN GARANTERES, HVIS DISSE ANVISNINGER FØLGES; SØRG DERFOR FOR AT GEMME DEM.

N ADVARSEL:

SIKKERHETEN TIL DETTE APPARATET GARANTERES KUN HVIS DU OVERHOLDER DISSE INSTRUKSJONENE; HUSK Å OPPBEVARE DEM PÅ ET TRYGT STED.

S OBSERVERA!

UTRUSTNINGENS SÄKERHET KAN ENDAST GARANTERAS OM DESSA ANVISNINGAR RESPEKTERAS I DETALJ. SPARA DÄRFÖR DESSA ANVISNINGAR FÖR FRAMTIDA KONSULTATION.

RUS ВНИМАНИЕ:

МЫ ГАРАНТИРУЕМ БЕЗОПАСНУЮ ЭКСПЛУАТАЦИЮ ИЗДЕЛИЯ ТОЛЬКО ПРИ СОБЛЮДЕНИИ СЛЕДУЮЩИХ ИНСТРУКЦИЙ; С ЭТОЙ ЦЕЛЬЮ НЕОБХОДИМО СОХРАНИТЬ ДАННУЮ БРОШЮРУ.

CN 警告

为确保该装置安全，请遵守操作指示；并于安全场所放置。



INSTALLAZIONE A SOSPENSIONE
SUSPENSION INSTALLATION
INSTALLATION EN SUSPENSION
INSTALLATION MIT STAHLSEILAUFHÄNGUNG
HET OPHANGEN
INSTALACION COLGADA
PENDLENDE OPHÆNG
HENGESTALLASJON
HÄNGANDE INSTALLATION
ПОДВЕСНОЙ МОНТАЖ
吊頂式安裝

START

	L START (mm)	P (mm)
2 x 	612	512
	1208	1108
	2397	2297
	3596	3496

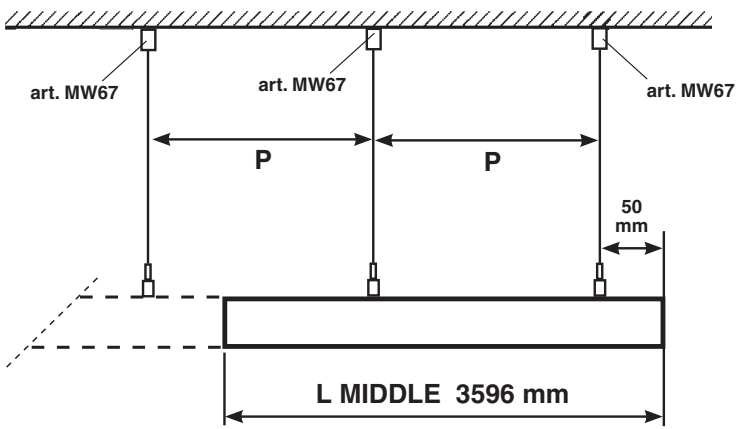
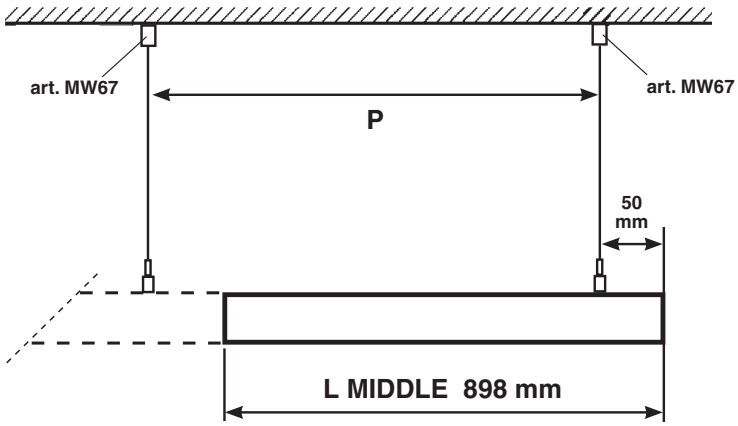

MIDDLE/END

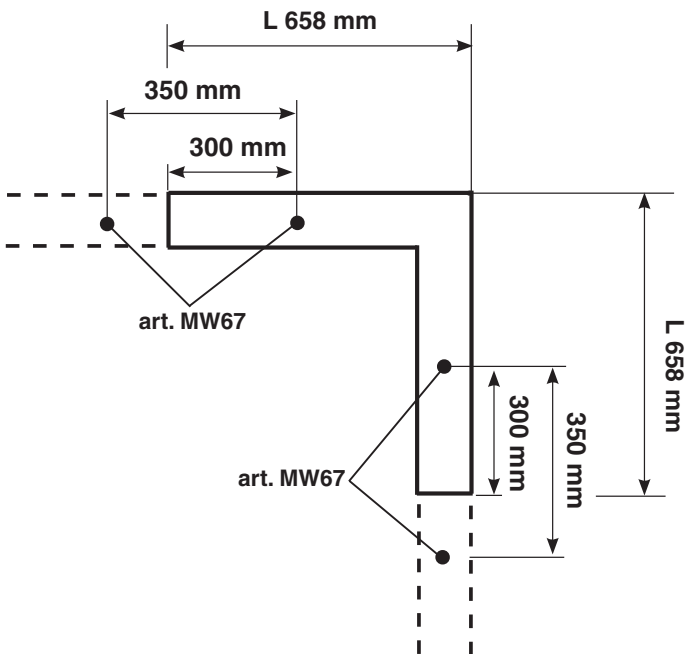

	L MIDDLE (mm)	P (mm)
1 x 	898	898
2 x  	3596	1798

90°



	L (mm)
2 x  	658 x 658

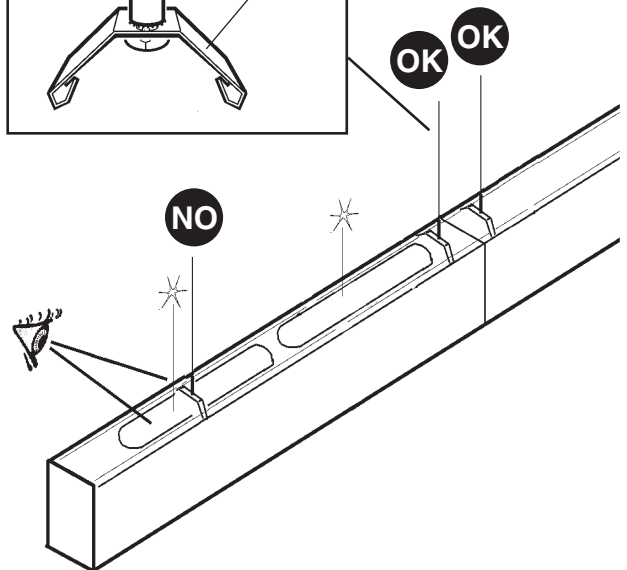
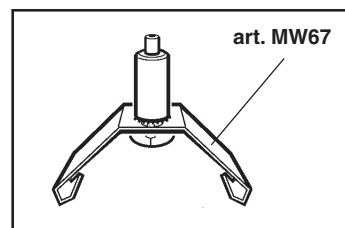
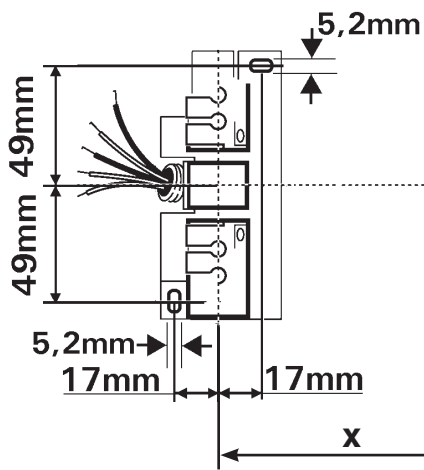
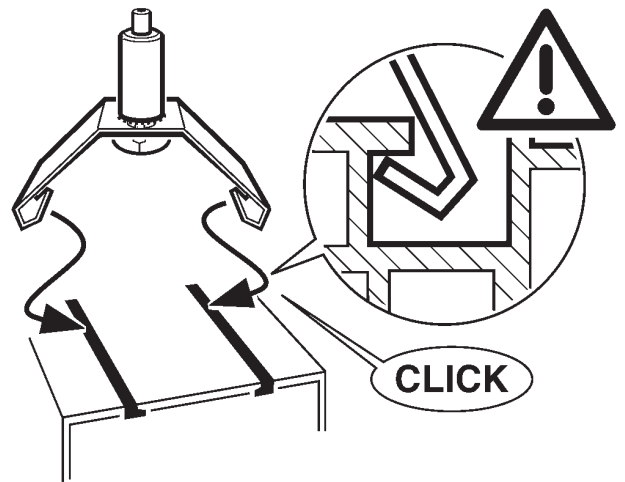
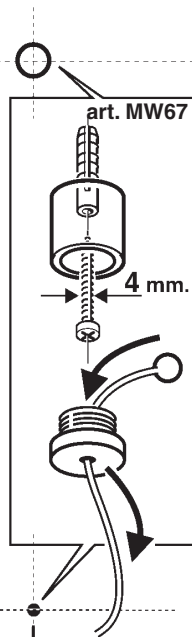
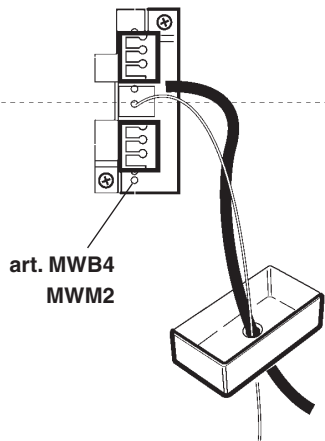
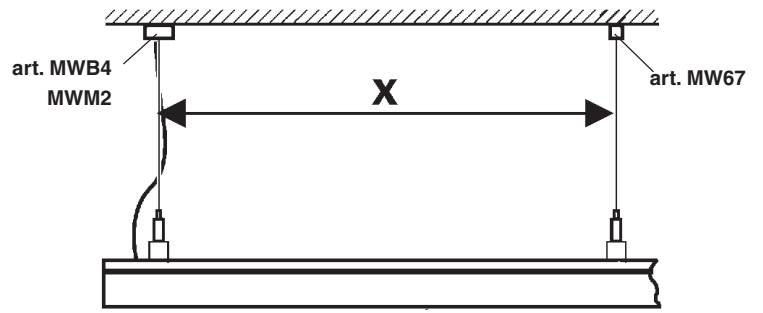
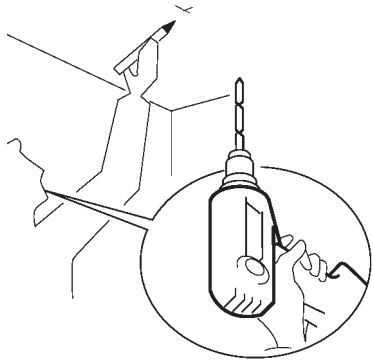

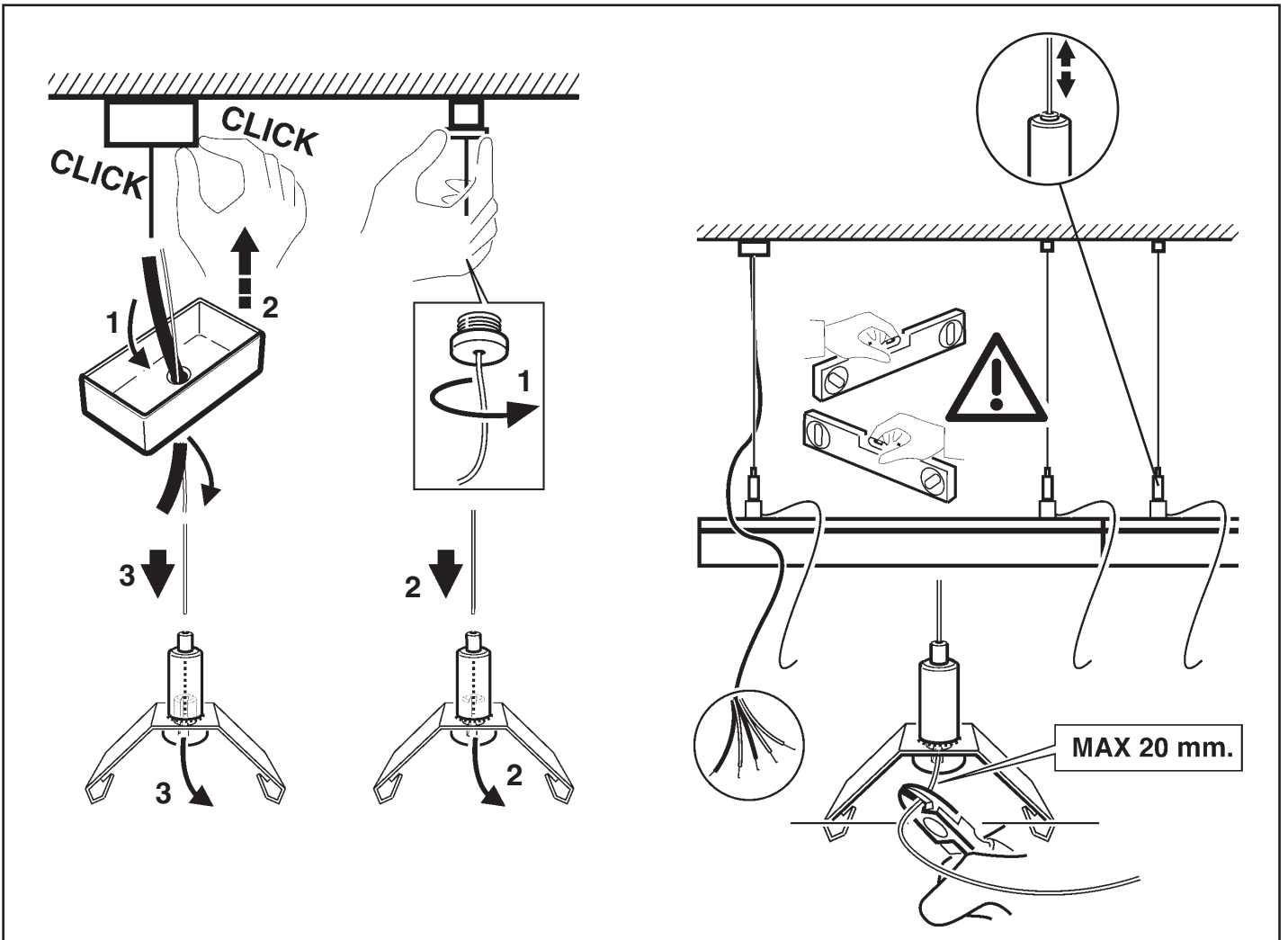
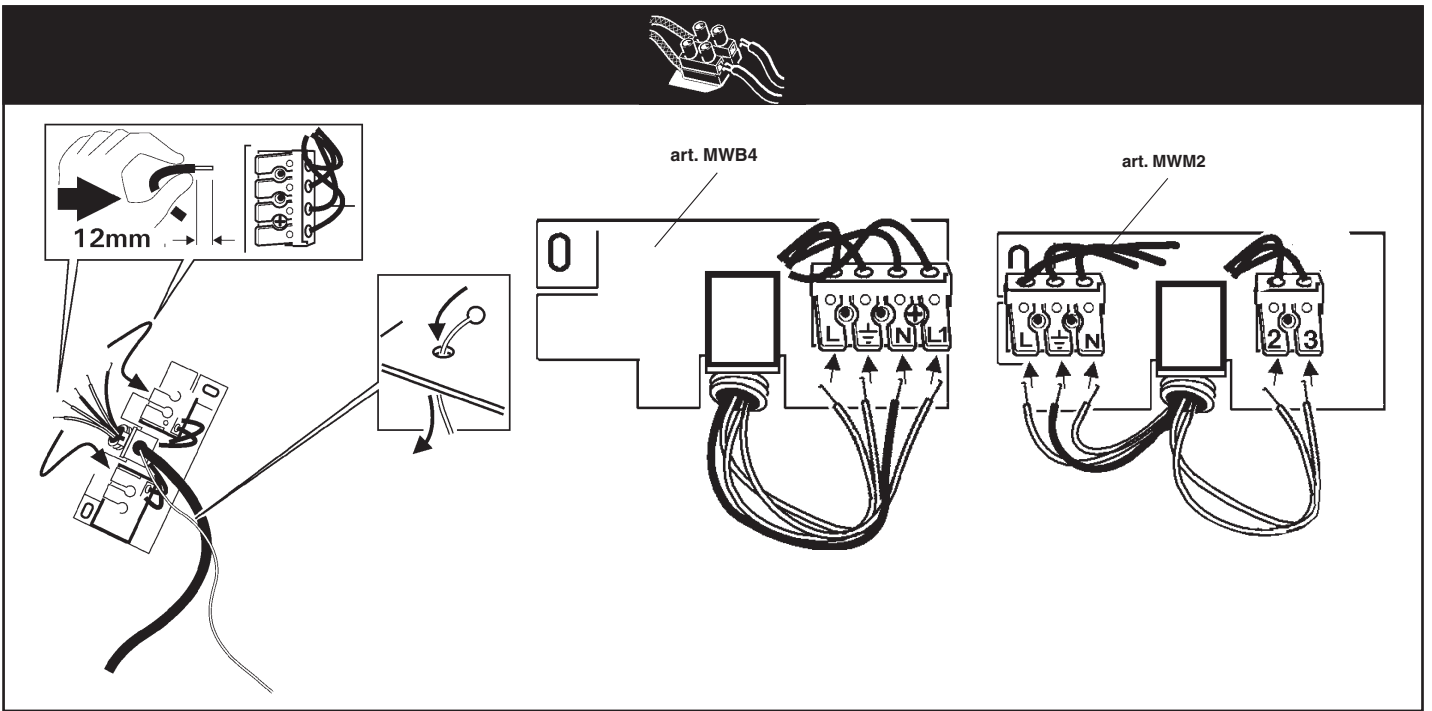

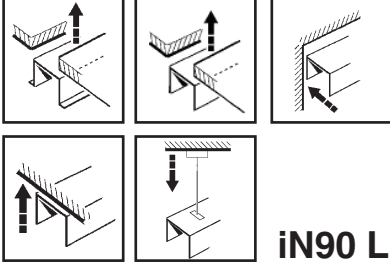

iN90 LED

AR **تحذير:**
لا يمكن ضمان سلامة هذا الجهاز إلا إذا التزمت بهذه التعليمات. يجب حفظها في مكان آمن.

IT **ATTENZIONE:**
LA SICUREZZA DELL'APPARECCHIO E' GARANTITA SOLO CON L'USO APPROPRIATO DELLE SEGUENTI ISTRUZIONI; PERTANTO E' NECESSARIO CONSERVARLE.

EN **WARNING:**
THE SAFETY OF THIS FIXTURE IS GUARANTEED ONLY IF YOU COMPLY WITH THESE INSTRUCTIONS; REMEMBER TO CONSERVE IN A SAFE PLACE.

ES **ATENCIÓN:**
LA SEGURIDAD DEL APARATO SE GARANTIZA SOLO CUMPLIENDO CUIDADOSAMENTE LAS SIGUIENTES INSTRUCCIONES; POR ELLO, ES NECESARIO CONSERVARLAS.

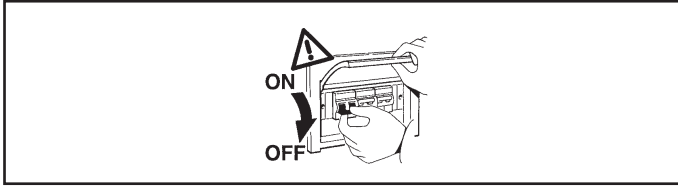

AR **ملاحظة: ملاحظة: أثناء تركيب نظام بحرص بالنظم السائدة المتعلقة بالشبكة الكهربائية.**

IT **N.B.:** DURANTE L'INSTALLAZIONE DEL SISTEMA RISPETTARE SCRUPolosAMENTE LE NORME IMPIANTISTICHE VIGENTI.

EN **N.B.:** WHEN INSTALLING THE SYSTEM STRICTLY COMPLY WITH ALL REGULATIONS ON INSTALLATION IN FORCE.

ES **N.B.:** DURANTE LA INSTALACIÓN DEL SISTEMA RESPETAR ESCRUPulosAMENTE LAS NORMAS DE INSTALACIÓN VIGENTES.

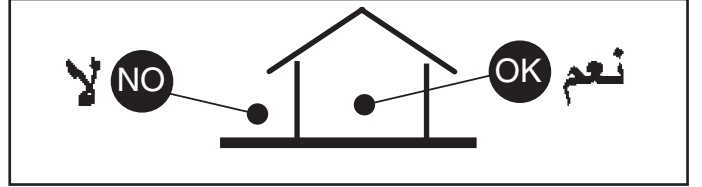

التركيب على السقف

INSTALLAZIONE SUL CONTROSOFFITTO
INSTALLATION ON CEILING
INSTALACION SOBRE FALSO TECHO

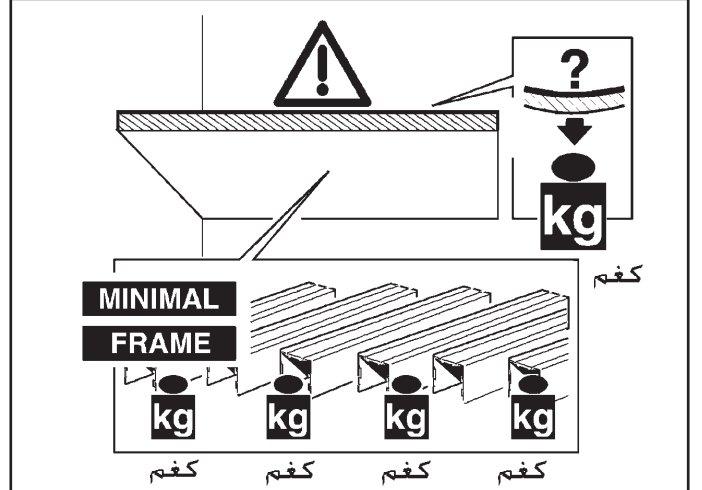

AR **ملاحظة: مسؤولية الفني التأكد من متانة السقف وهل قادر على تحمل الأجهز التي سوف تركيب عليه انظر الى**

IT **N.B.:** E' responsabilità dell'utente verificare la resistenza del controsoffitto, in funzione del peso degli apparecchi installati.

EN **N.B.:** It is the user's responsibility to check the strength of the false ceiling with respect to the weight of the fixtures installed (see table).

ES **NOTA:** Corresponde al usuario efectuar las pruebas en el falso techo, en función del peso de los aparatos instalados (véase tabla).

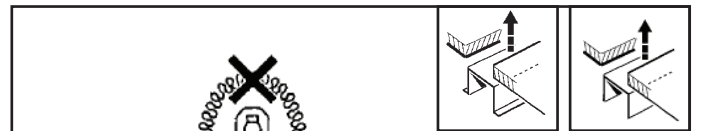

AR **ملاحظة: أجهزة غير قابلة للتغطية مواد عازلة حرارياً.**

IT **N.B.:** Apparecchi non idonei ad essere coperti di materiale termicamente isolante

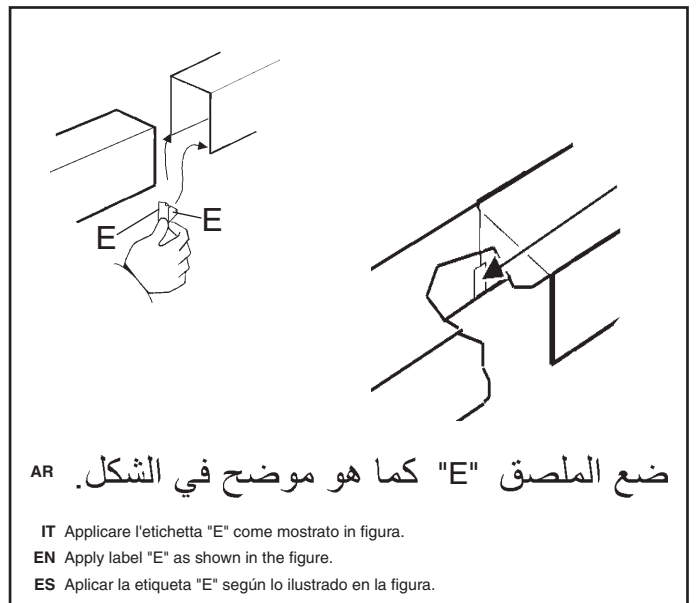
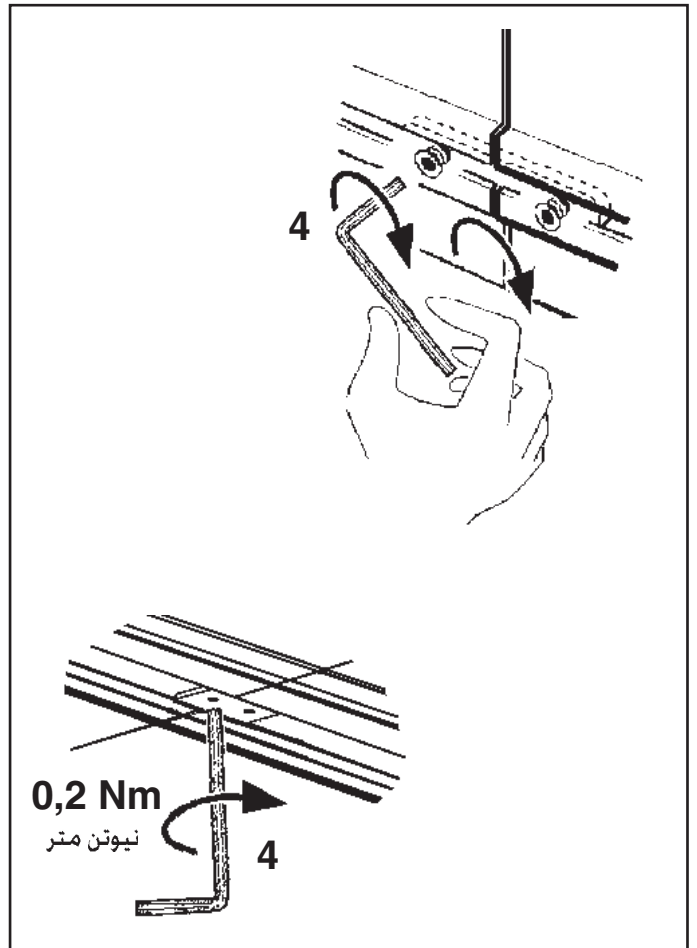
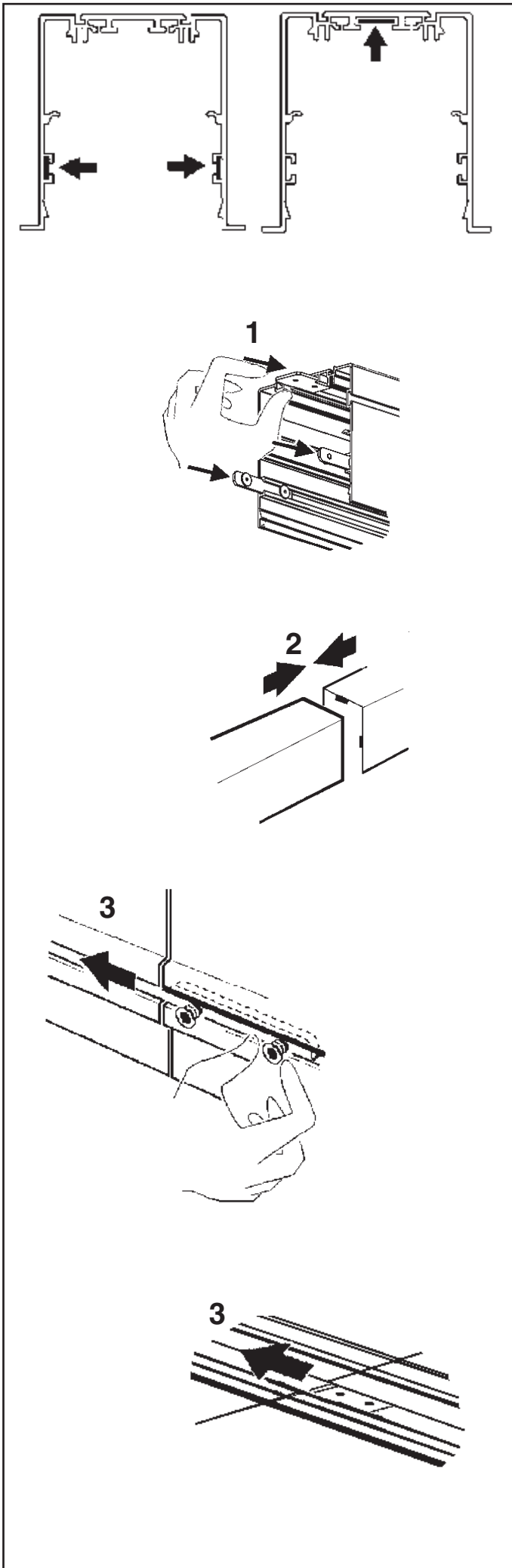

EN **N.B.:** Fixtures not suitable to be covered in thermally-insulating material.

ES **OBS!** Utrustningen får inte täckas över med värmeisolerande material

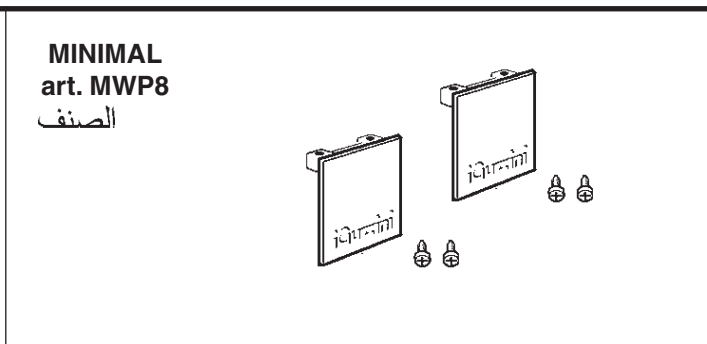
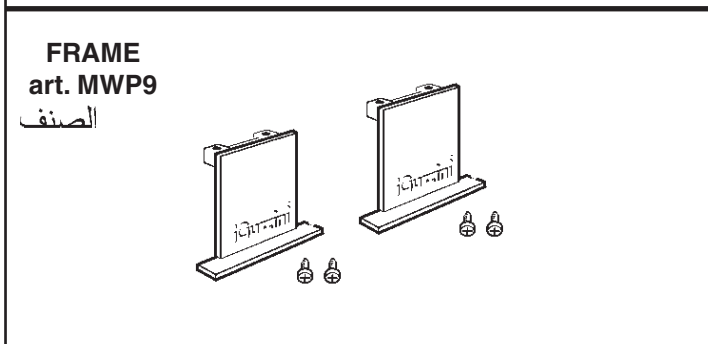
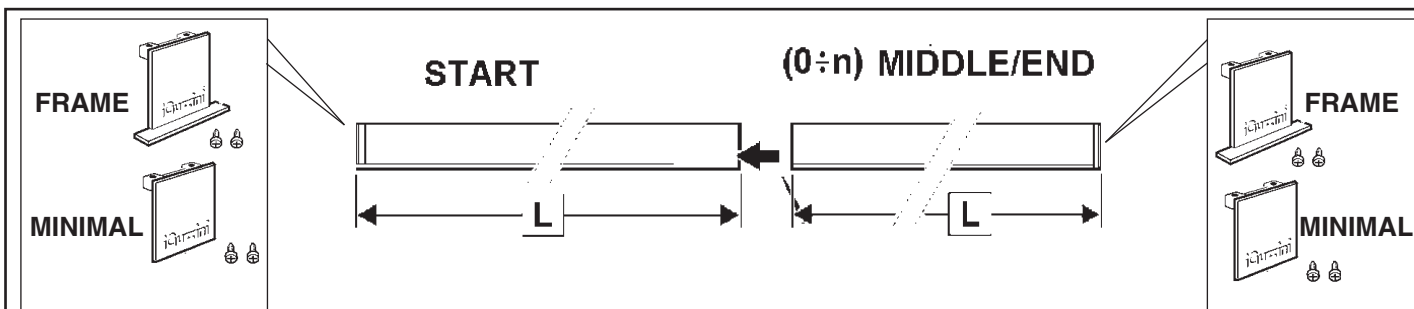





UP/ DOWN

TYPE	L (mm) ملم	الصنف ART.	START	MIDDLE/END	
 GENERAL LIGHTING LOW CONTRAST	1208	Q368	●		Q416 - Q417 - Q418 - Q419
	2397	Q369	●		2x Q416 - Q417 - Q418 - Q419
	3596	Q370	●		QH89 - QH90 - QH91 - QH92
	3596	Q371		●	QH89 - QH90 - QH91 - QH92
 UGR <19°	1208	Q432	●		Q456 - Q457 - Q458 - Q459
	2397	Q433	●		2x Q456 - Q457 - Q458 - Q459
	3596	Q434	●		QH97 - QH98 - QH99 - QI00
	3596	Q435		●	QH97 - QH98 - QH99 - QI00

DOWN

TYPE	L (mm) ملم	الصنف ART.	START	MIDDLE/END	
 GENERAL LIGHTING LOW CONTRAST	612	Q356 - Q362 - R401 - R407	●		Q404 - Q407 - Q410 - Q413
	898	Q360 - Q366 - R405 - R411		●	Q405 - Q408 - Q411 - Q414
	1208	Q357 - Q363 - R402 - R408	●		Q406 - Q409 - Q412 - Q415
	2397	Q358 - Q364 - R403 - R409	●		2x Q406 - Q409 - Q412 - Q415
	3596	Q359 - Q365 - R404 - R410	●		QH85 - QH86 - QH87 - QH88
	3596	Q361 - Q367 - R406 - R412		●	QH85 - QH86 - QH87 - QH88
 UGR <19°	612	Q420 - Q426 - R421 - R427	●		Q444 - Q447 - Q450 - Q453
	898	Q424 - Q430 - R425 - R431		●	Q445 - Q448 - Q451 - Q454
	1208	Q421 - Q427 - R422 - R428	●		Q446 - Q449 - Q452 - Q455
	2397	Q422 - Q428 - R423 - R429	●		2x Q446 - Q449 - Q452 - Q455
	3596	Q423 - Q429 - R424 - R430	●		QH93 - QH94 - QH95 - QH96
	3596	Q425 - Q431 - R426 - R432		●	QH93 - QH94 - QH95 - QH96

EXAMPLES:

مصدر التيار
ALIMENTAZIONE
POWER SUPPLY
CEBADOR

مصدر التيار
ALIMENTAZIONE
POWER SUPPLY
CEBADOR

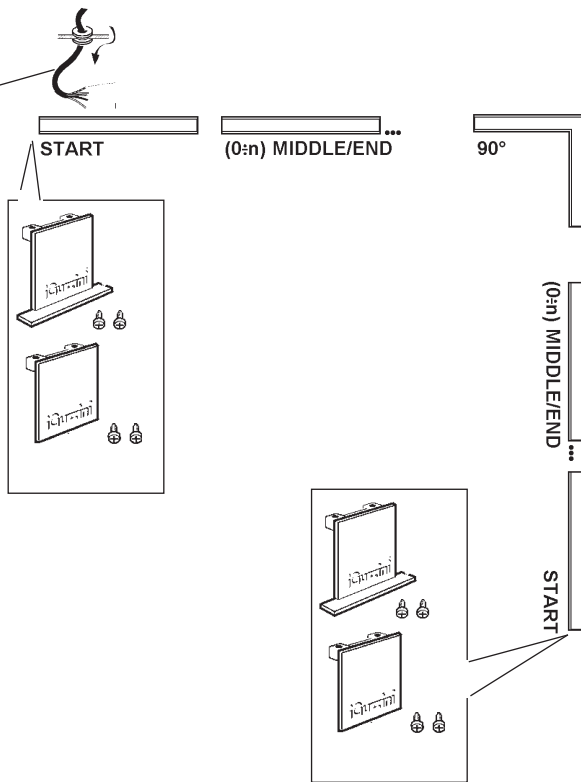
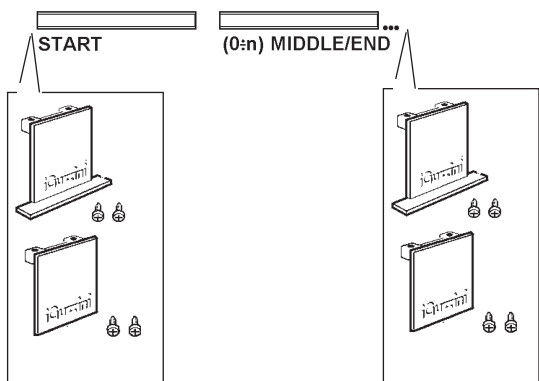

مصدر التيار
ALIMENTAZIONE
POWER SUPPLY
CEBADOR

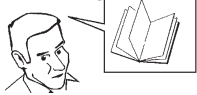
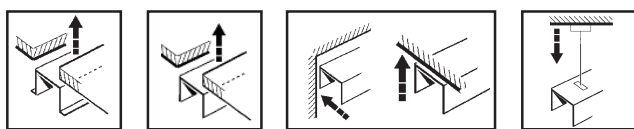
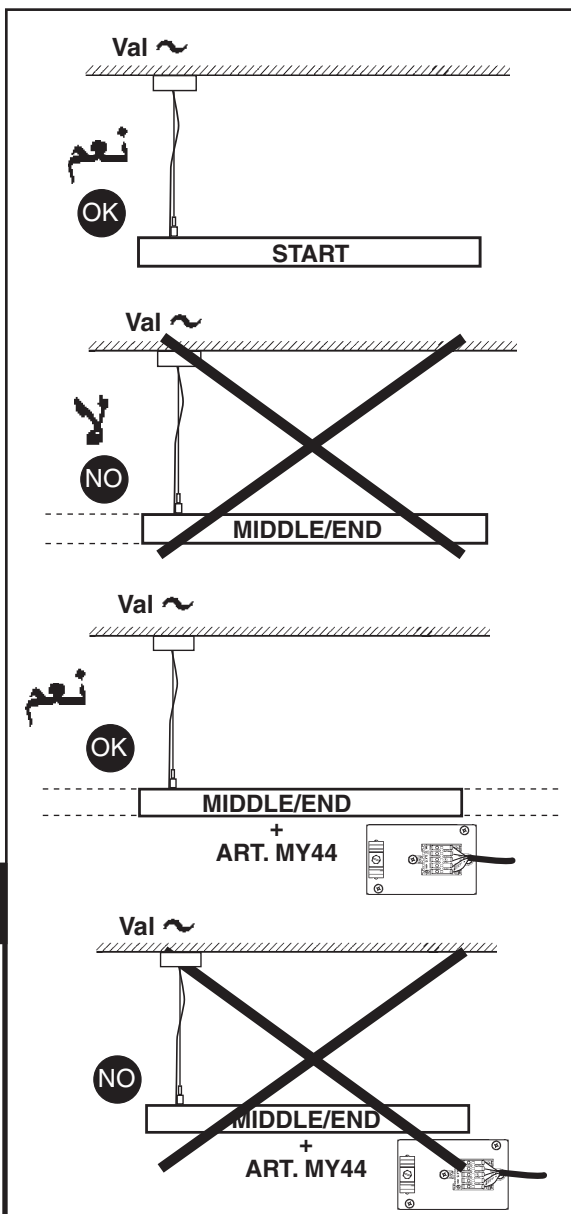
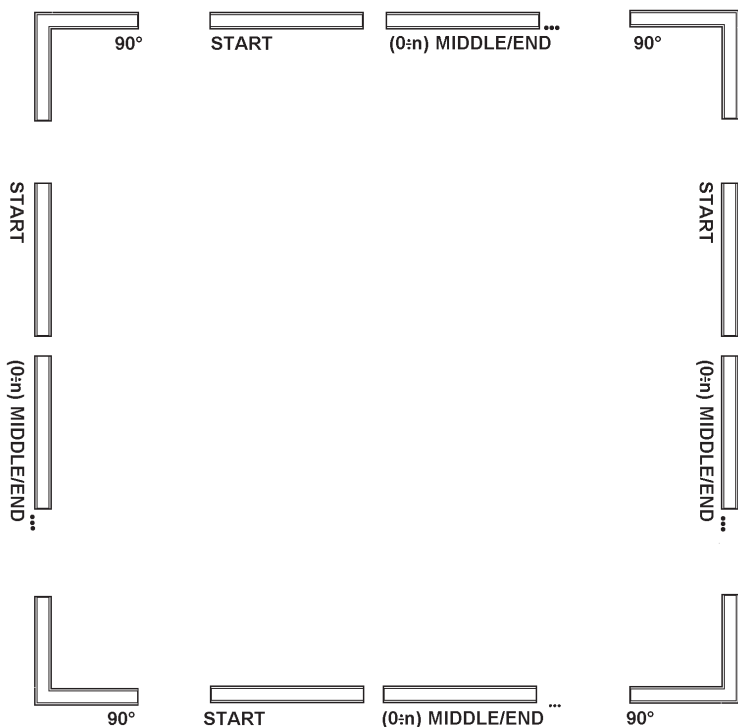



تحديد أقصى حد للتيارات المسموح بها

DETERMINAZIONE DELLE CORRENTI MASSIME AMMISSIBILI
DETERMINING THE MAXIMUM PERMITTED CURRENT
DETERMINACIÓN DE LAS CORRIENTES MÁXIMAS PERMITIDAS

AR يجب - عند تصميم جهاز الإضاءة والكهرباء - أن يتم تحديد أقصى تيارات كهربائية مسموح بها، وذلك مع أخذ العوامل التالية بعين الاعتبار:
- الحصول على التيار الكهربائي الاسمي المسموح به، من خلال شرائح التوصيل الممزقة بالرمز MAX 9A، وذلك بالنسبة لكليل المر بين الوحدات المختلفة؛
- معامل الأمان، بحيث يؤخذ بعين الاعتبار الجهود الكهربائية الزائدة، وكذلك فترات التشغيل؛
- الاستهلاك الاسمي الحالي لكل وحدة من الوحدات (انظر الجدول).

IT Nella progettazione dell'impianto illuminotecnico ed elettrico, determinare le correnti massime ammissibili, considerando i seguenti fattori:
- corrente nominale ammessa dalle morsettiere MAX 9A per cablaggio passante fra moduli;
- coefficiente di sicurezza per tenere conto delle sovratensioni e contemporaneità;
- corrente nominale assorbita dai singoli moduli (vedi tabella).

EN When designing the lighting and electrical systems, work out the maximum permitted current based on the following factors:
- rated current permitted by terminal blocks MAX 9 A for through wiring between modules;
- safety coefficient to allow for overvoltage and contemporaneity;
- rated current absorbed by single modules (see table).

ES Durante la proyectación de la instalación luminotécnica y eléctrica, determinar las corrientes máximas permitidas, en consideración de los factores siguientes:
- corriente nominal permitida por las clemas de conexión MAX 9A para cableado pasante entre módulos;
- coeficiente de seguridad para considerar sobretensiones y contemporaneidades;
- corriente nominal absorbida por los módulos individuales (ver tabla).

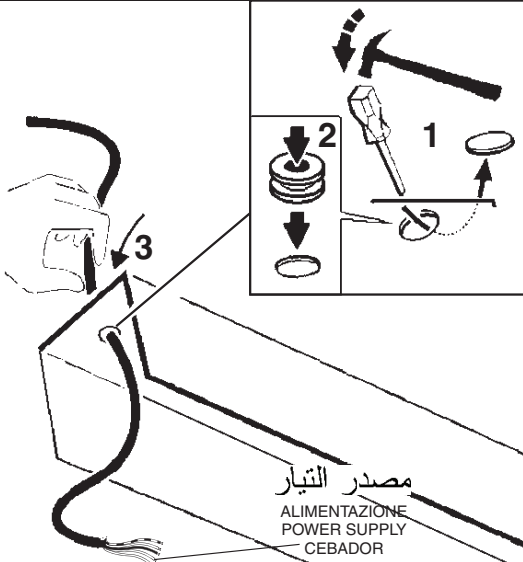

5



+ art. MY44

AR استخدم المكون MY44 كلما كان هناك ضرورة لاستخدام وصلة تطويل جديدة للطاقة .
(انظر جدول الحدود القصوى للتيار المسموح بها).

IT Utilizzare l'art. MY44 ogni qual volta è necessario effettuare una nuova calata di alimentazione (vedere tabella delle correnti massime ammissibili.)

EN Use item MY44 whenever it is necessary to effect a new power extension. (see maximum tolerable currents table)

ES Utilizar el art. MY44 cada vez que se necesite efectuar una nueva alimentación intermedia (véase la tabla de corrientes máximas permitidas)

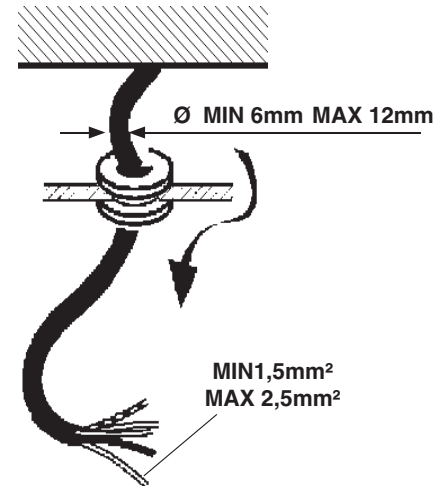
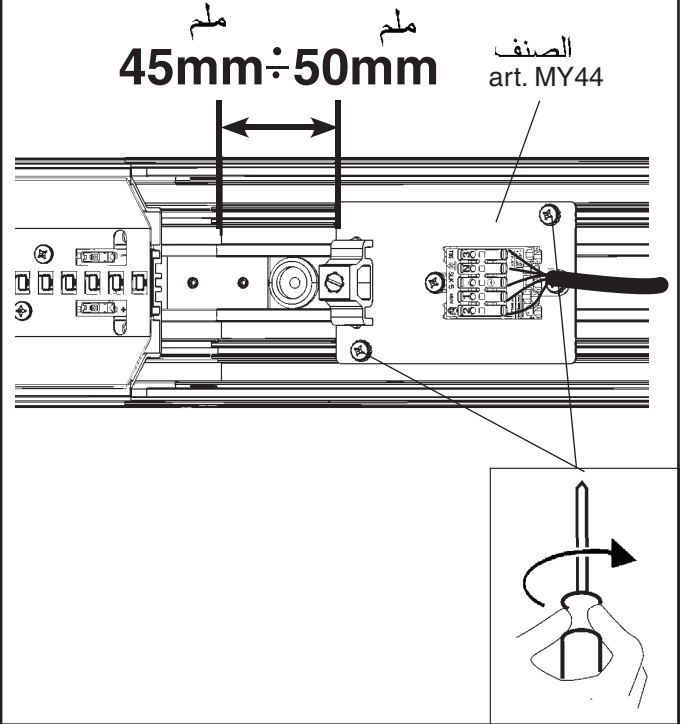

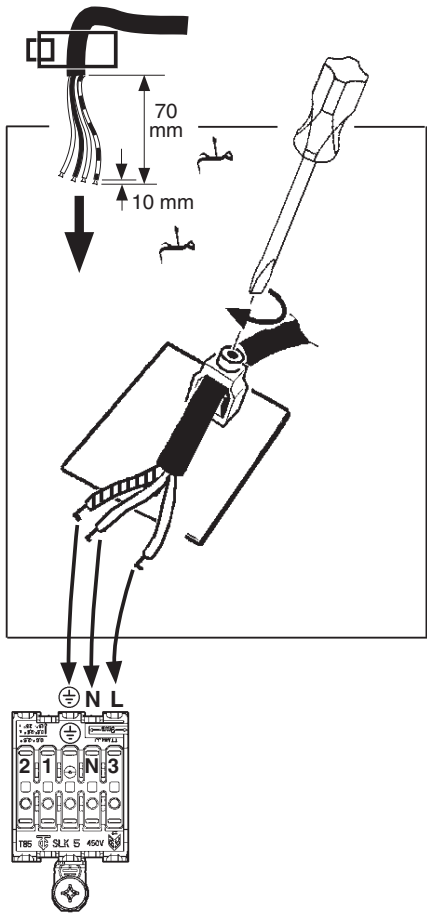

DALI

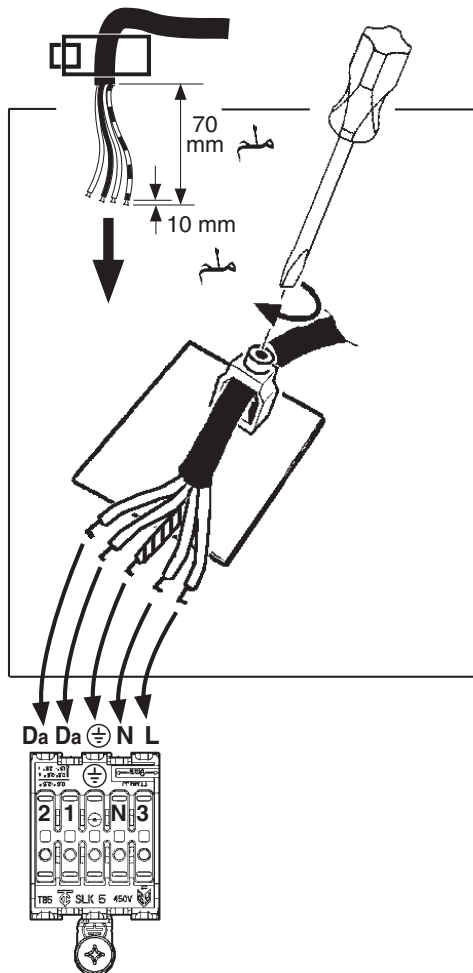

+ art. MWB4

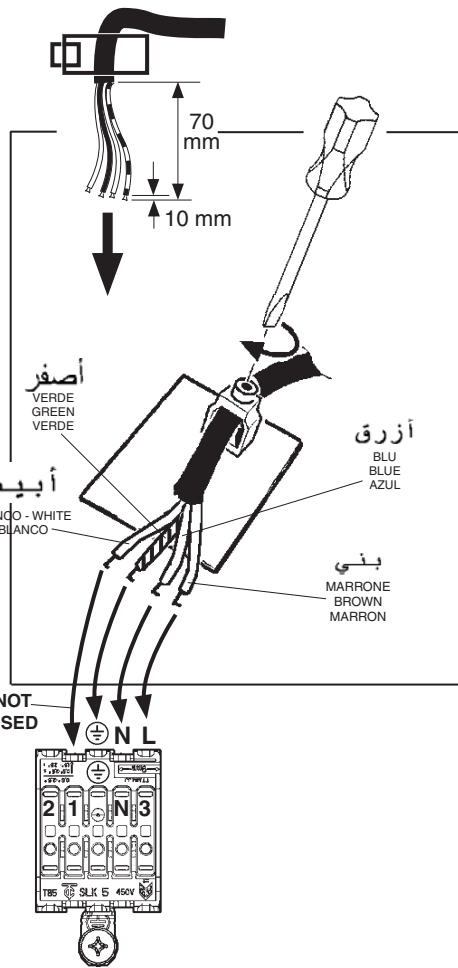

art. MWB4

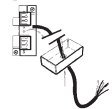

DALI

+ art. MWM2

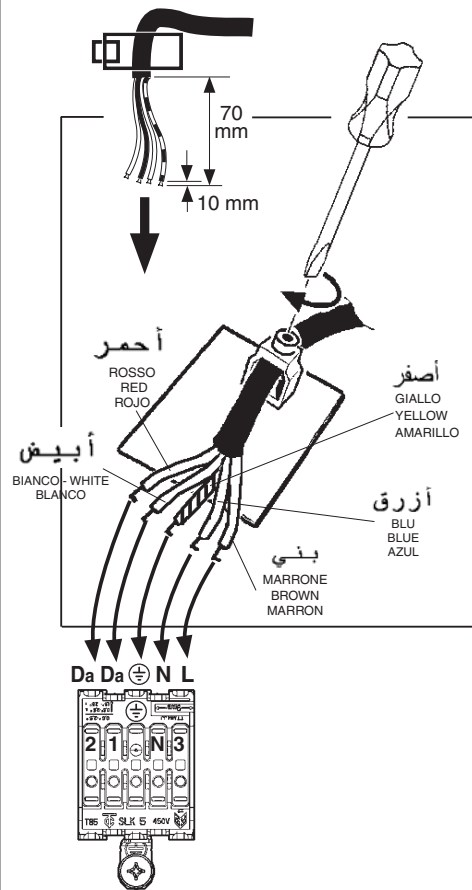

art. MWM2



DALI شحنة / DALI حمل CARICO DALI / DALI LOAD CHARGE DALI CARGA DALI	عناوين DALI INDIRIZZI DALI DALI ADDRESSES DIRECCIONES DALI
1 (2 mA)	1
ART. QH86 - QH88 - QH90 - QH92 2(4 mA)	2

TOUCH DIM

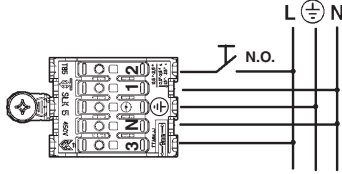

AR يمكن أن يتم تخفيض إضاءة الأجهزة ذات الكابلات الرقمية؛ وذلك عن طريق استخدام أجهزة الإمداد بالطاقة الكهربائية "دالي" (DALI)، أو عن طريق استخدام زر يكون مفتوحًا في وضعه الطبيعي (N.O.)؛ حيث يتم التوصيل كما هو مبين في المخطط.

IT I dispositivi con cablaggio digitale possono essere dimmerati con dispositivi DALI o con pulsante normalmente aperto (N.O.) da collegare come da schema.
EN Devices with digital control gear may be dimmed using DALI devices or a normally-open button (N.O.) to be connected as shown in the diagram.
ES Los dispositivos con cableado digital pueden regularse con dispositivos DALI o con un interruptor de botón normalmente abierto (N.O.) que se conecta según ilustrado en el esquema.

AR يمكن أن يتسبب التحكم في منتجات "دالي" المختلفة عن طريق الأزرار (مثل الأزرار: "تنتش - ديم"، "سويتش - ديم"، "بوش - ديم"، دايركت - ديم"، إلخ.)، في حدوث مشاكل تتعلق بعمليات التزامن بين هذه الأزرار. وإن كان من الممكن تجنب مثل هذه المشاكل، وذلك عن طريق تزويد بعض الأجهزة الإضافية ندعومك للاتصال بالشركة، وذلك للحصول على أكبر قدر من المعلومات.

IT Pilotare diversi prodotti DALI tramite pulsante (es: Touch-dim, Switch-dim, Push-dim, Direct-dim, etc.) potrebbe causare dei problemi di sincronizzazione tra gli stessi. È possibile ovviare a questo problema dotandosi di dispositivi aggiuntivi. Per maggiori informazioni vi invitiamo a contattarci direttamente.
EN Controlling different DALI products through buttons (e.g.: Touch-dim, Switch-dim, Push-dim, Direct-dim, etc.) may lead to product synchronisation problems. This problem can be overcome by using additional devices. For further information, please contact us directly.
ES El mando de varios productos DALI por tecla (ej: Touch-dim, Switch-dim, Push-dim, Direct-dim, etc.) podría causar problemas de sincronización entre ellos. Es posible prevenir este problema utilizando dispositivos adicionales. Para más información, contacte directamente con nosotros.

EXAMPLE:



START

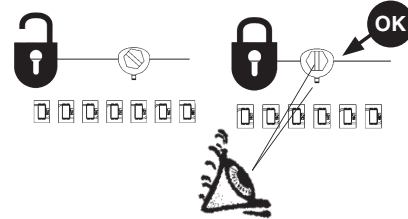
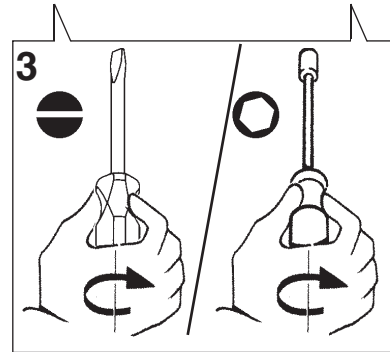
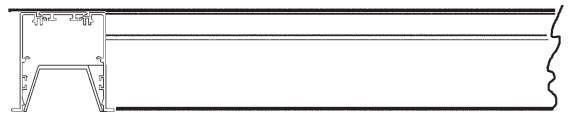
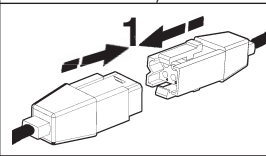
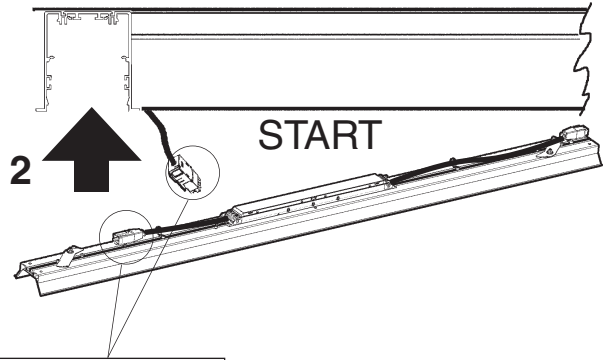

EXAMPLE:



START/ MIDDLE

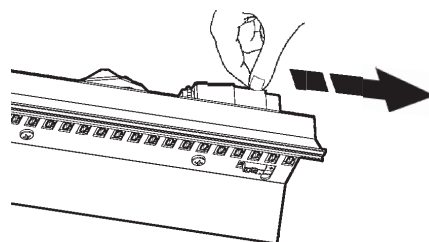

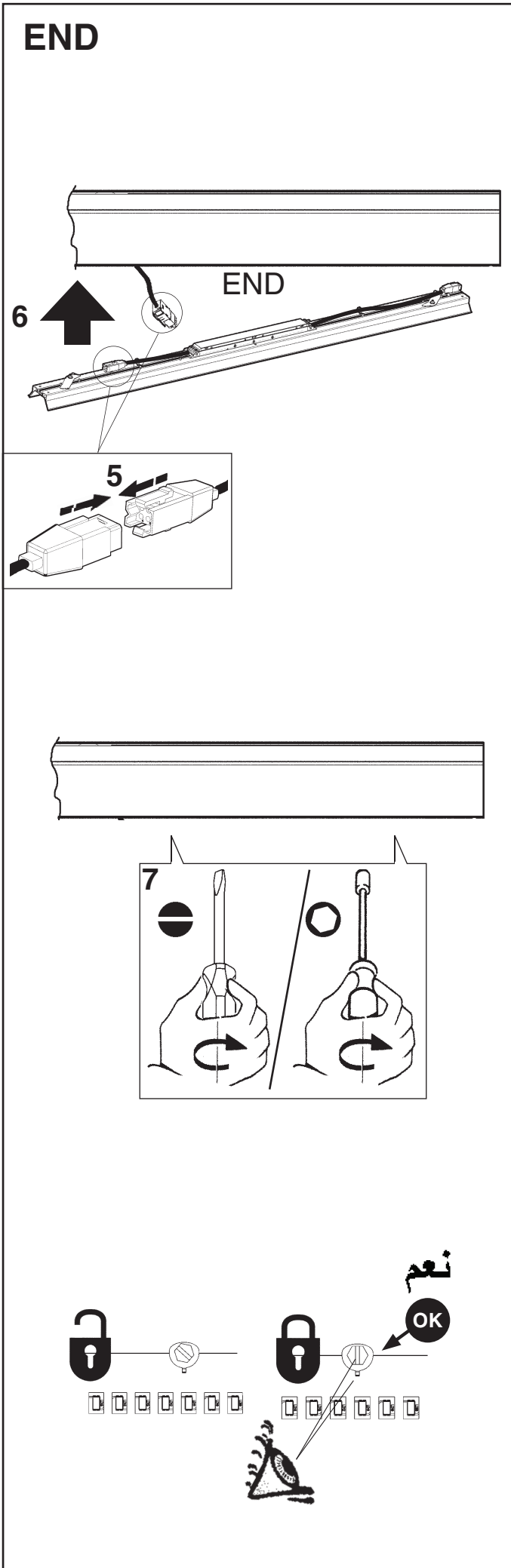
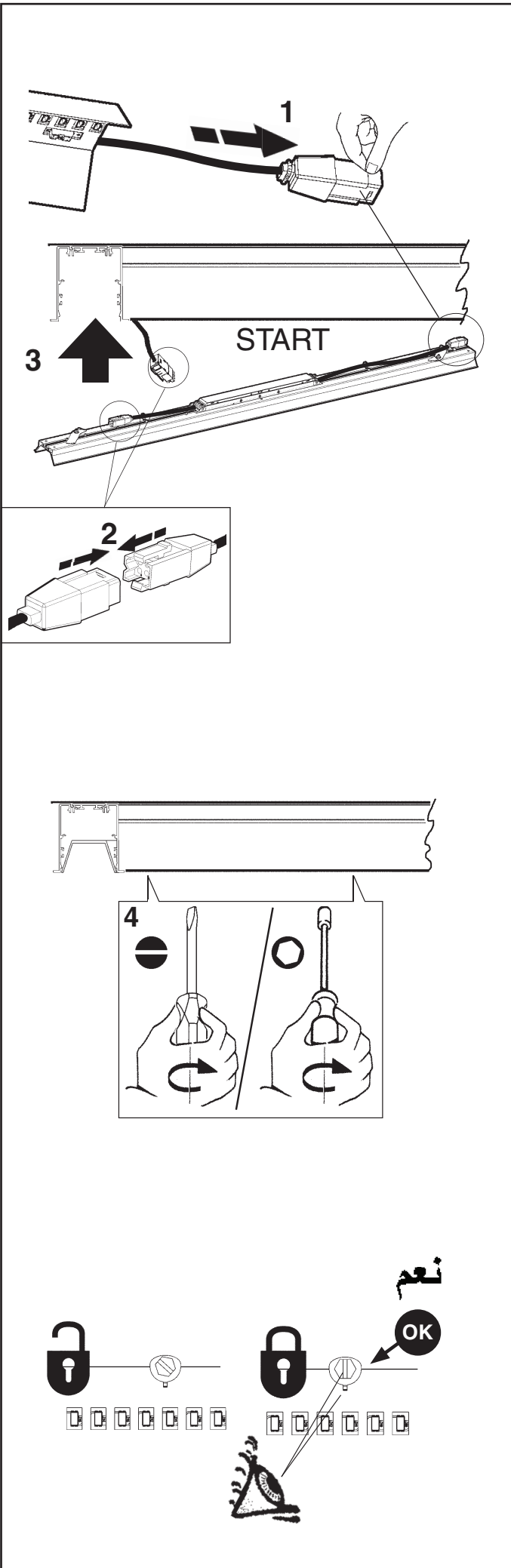

EXAMPLE:

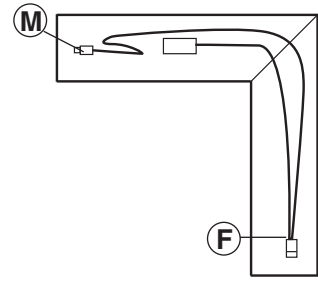
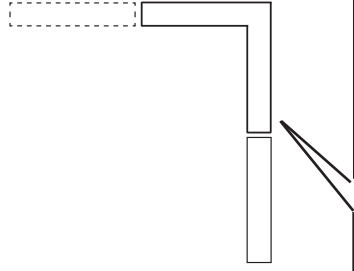
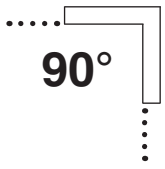

EXAMPLE:

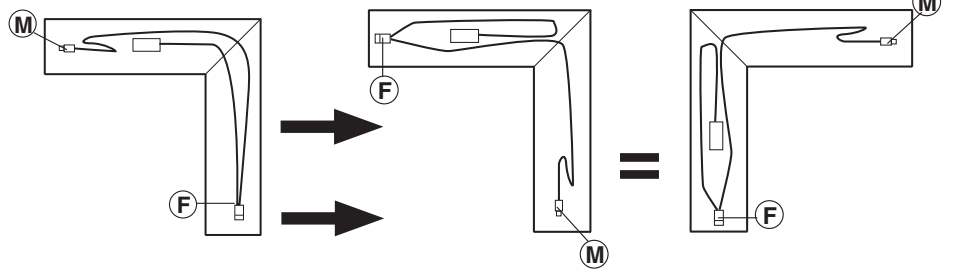
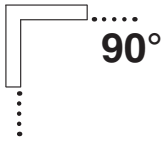

M

مذکر
Maschio
Male
Macho

F

مؤنث
Femina
Female
Hembra

M

F

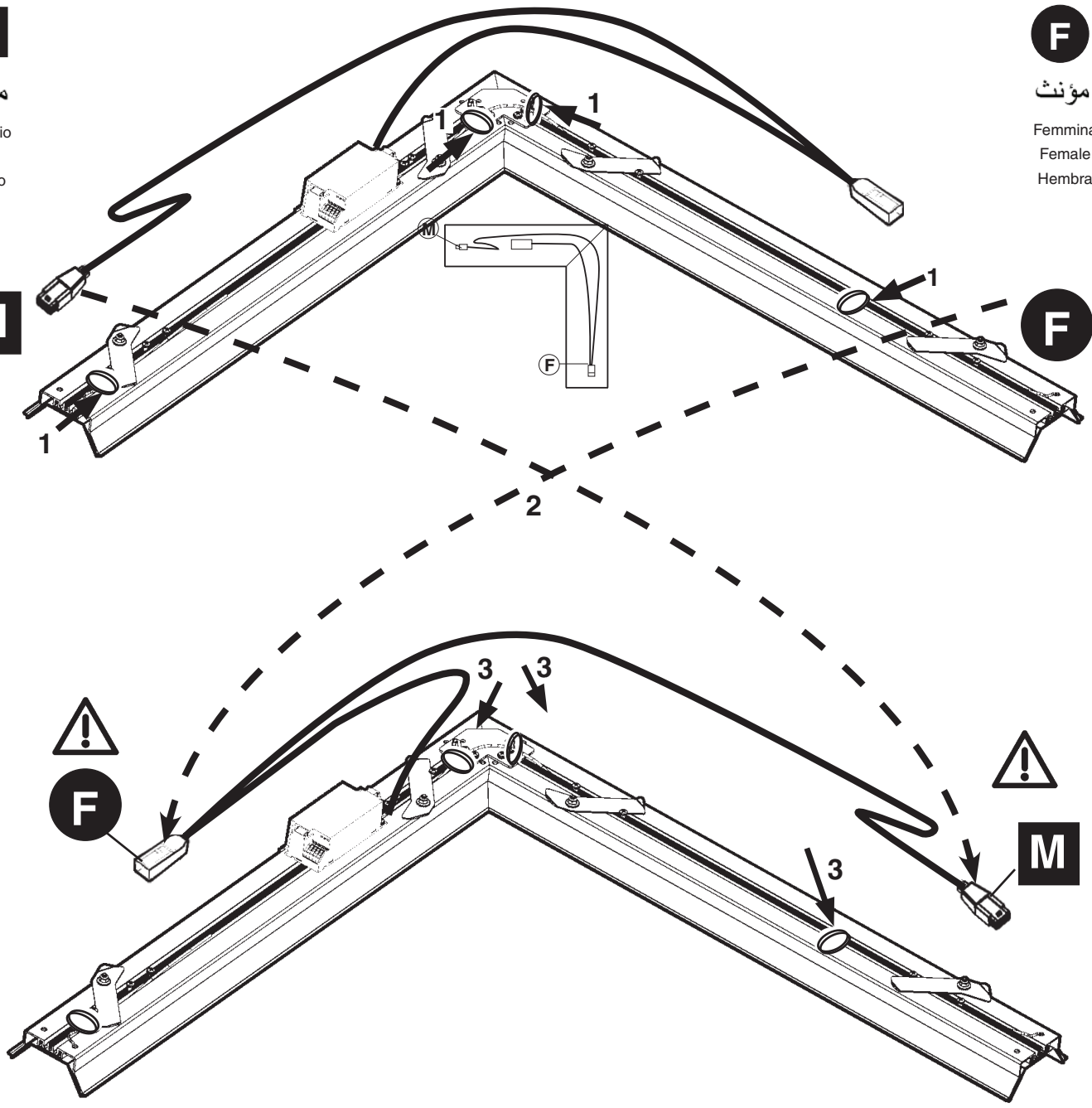

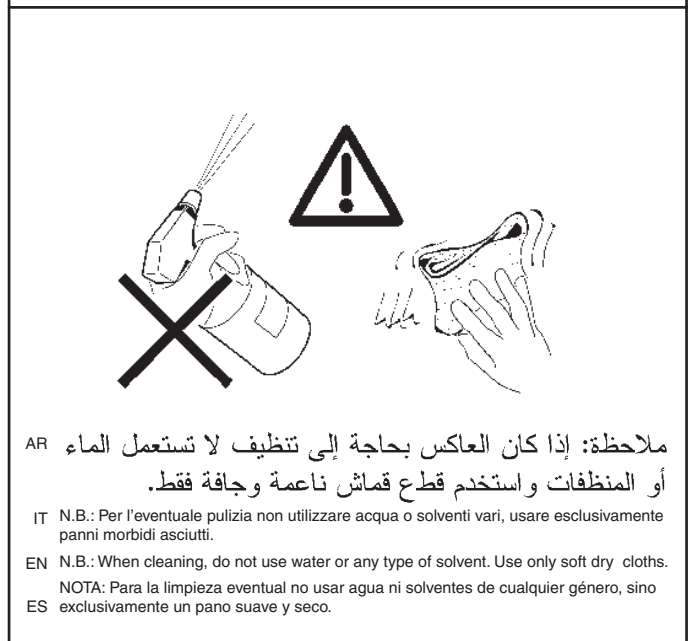
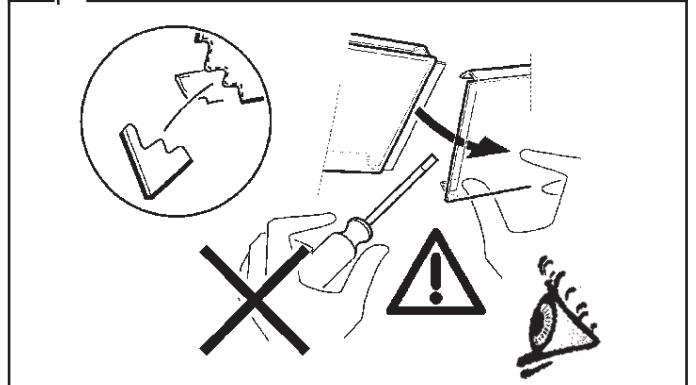
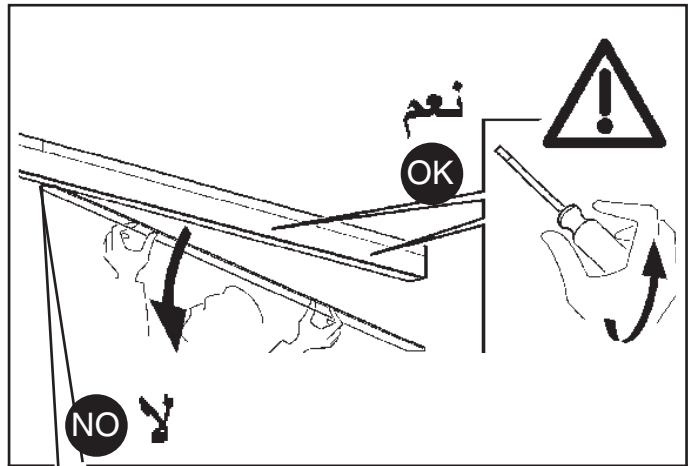
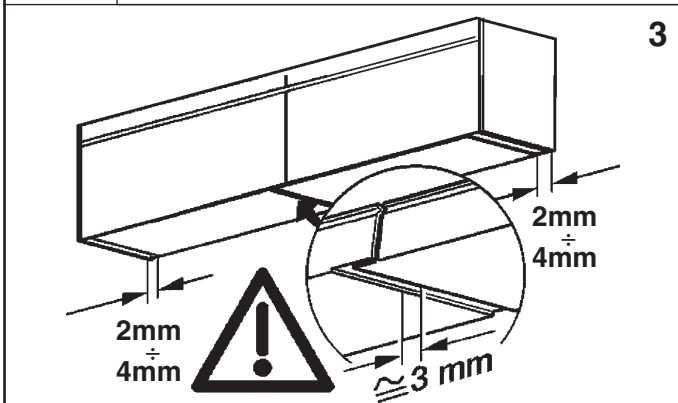
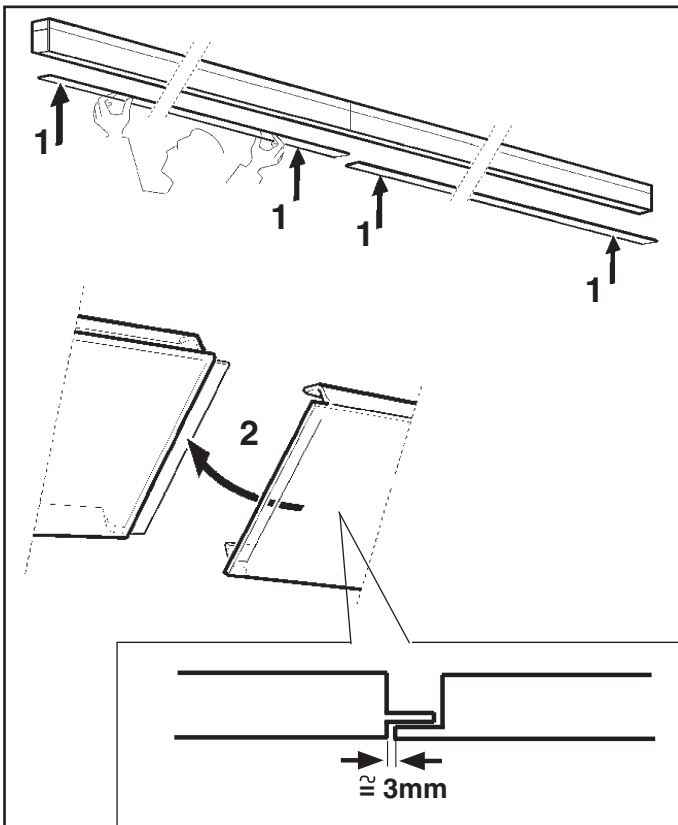
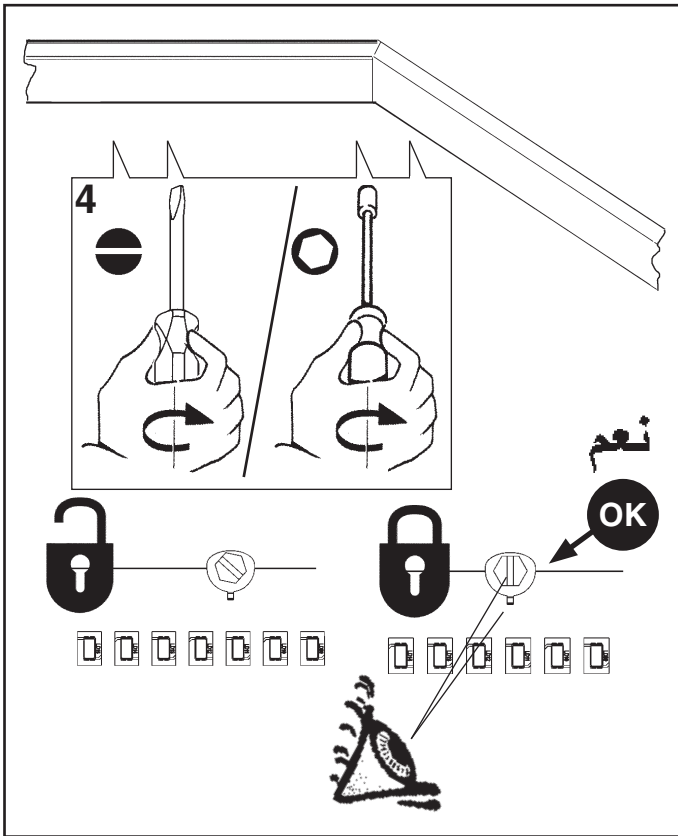

AR **تنبيه: لاستبدال الضوء LED اتصل بشركة iGuzzini**

IT N.B.: Per la sostituzione del LED contattare l'azienda iGuzzini.

EN N.B.: For information on LED replacement please contact iGuzzini.

ES **NOTA:** Para sustituir el LED llame a la empresa iGuzzini.

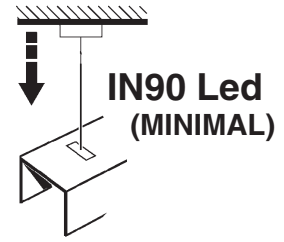

AR

تحذير:

لا يمكن ضمان سلامة هذا الجهاز إلا إذا التزمت بهذه التعليمات، يجب حفظها في مكان آمن.

IT ATTENZIONE:

LA SICUREZZA DELL'APPARECCHIO E' GARANTITA SOLO CON L'USO APPROPRIATO DELLE SEGUENTI ISTRUZIONI; PERTANTO E' NECESSARIO CONSERVARLE.

EN WARNING:

THE SAFETY OF THIS FIXTURE IS GUARANTEED ONLY IF YOU COMPLY WITH THESE INSTRUCTIONS; REMEMBER TO CONSERVE IN A SAFE PLACE.

ES ATENCION:

LA SEGURIDAD DEL APARATO SE GARANTIZA SOLO CUMPLIENDO CUIDADOSAMENTE LAS SIGUIENTES INSTRUCCIONES; POR ELLO, ES NECESARIO CONSERVARLAS.



تركيب بالتعليق

INSTALLAZIONE A SOSPENSIONE
SUSPENSION INSTALLATION
INSTALACION COLGADA

	L START (mm) ملم	P (mm) ملم
2 x	612	512
	1208	1108
	2397	2297
	3596	3496

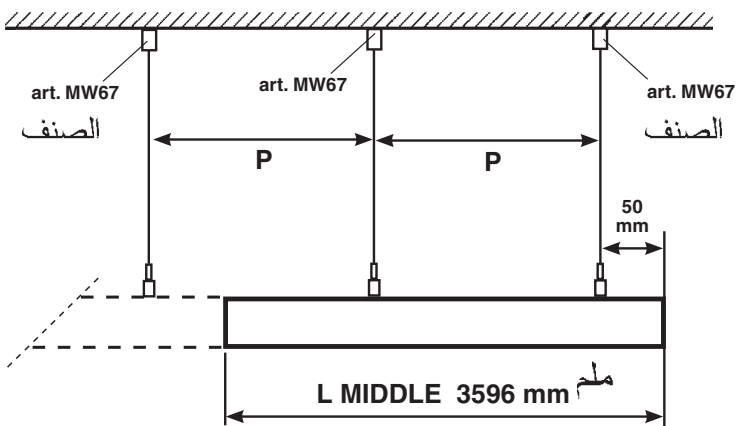
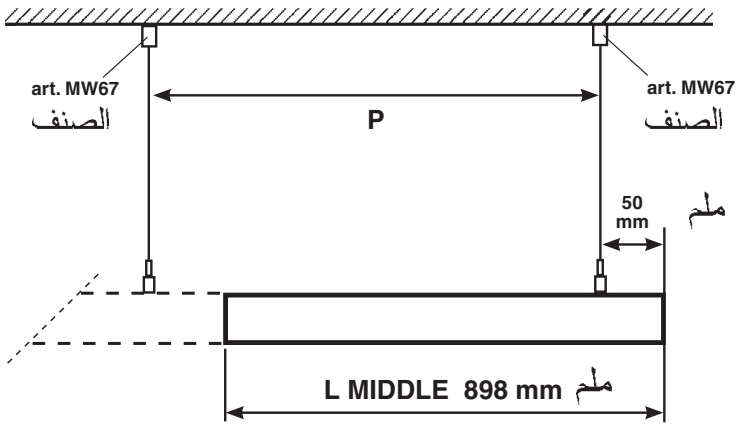

MIDDLE/END

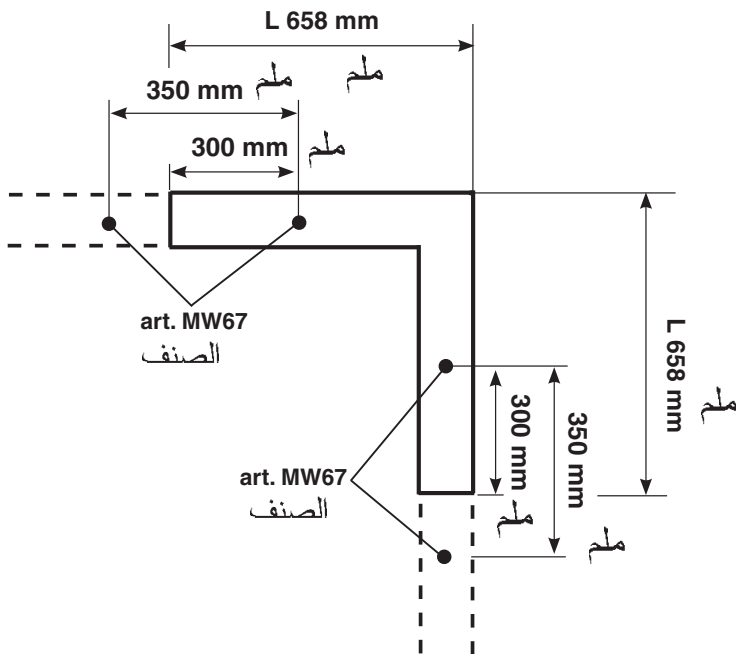

	L MIDDLE (mm)	P (mm) ملم
1 x 	898	898
2 x  	3596	1798

90°



	L (mm) ملم
2 x  	658 x 658

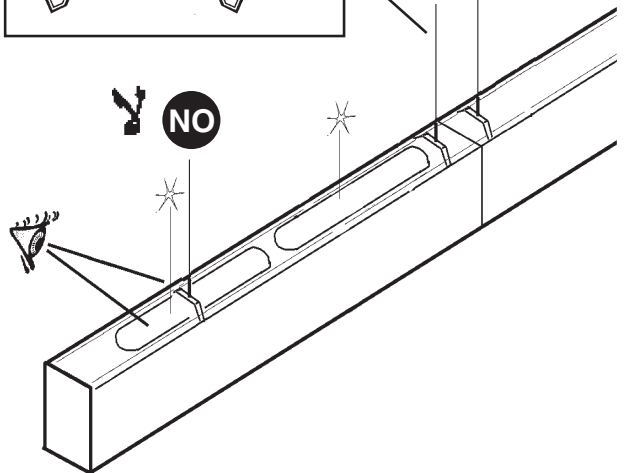
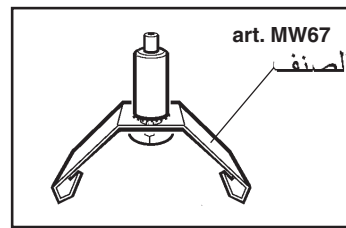
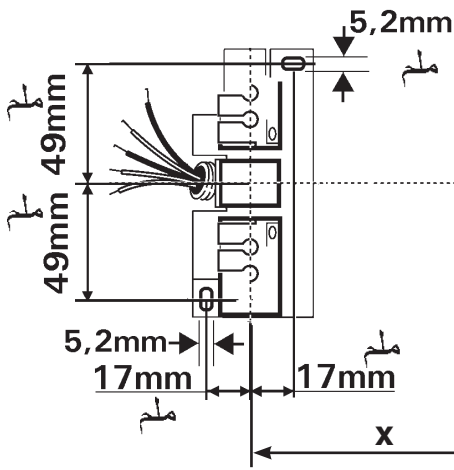
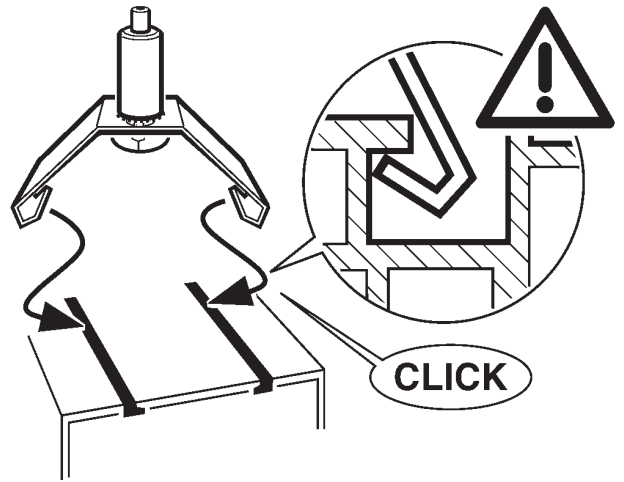
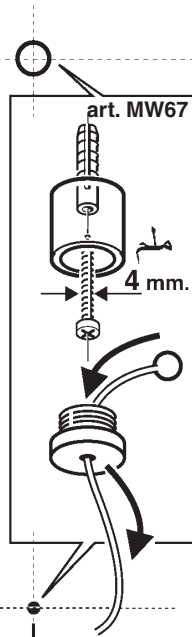
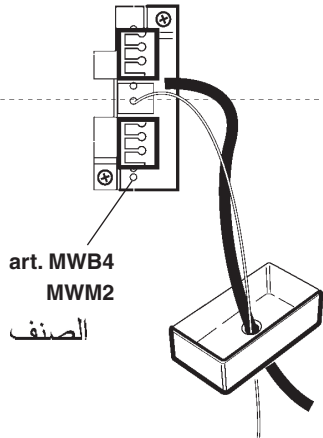
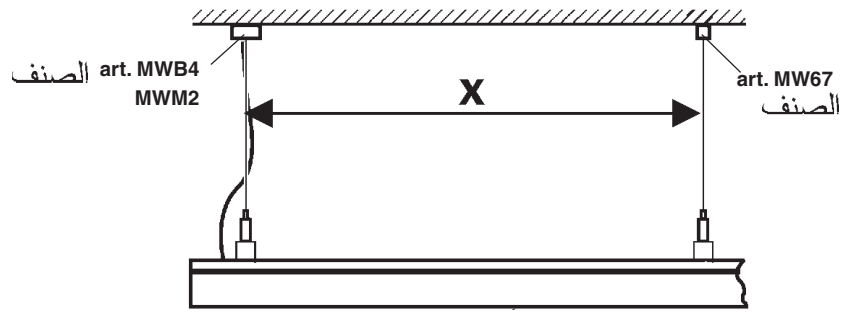
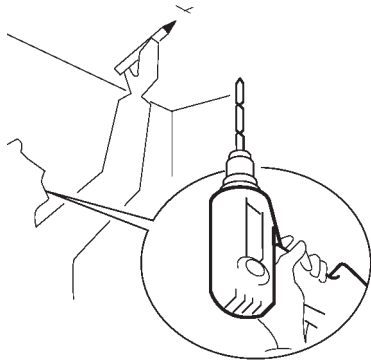

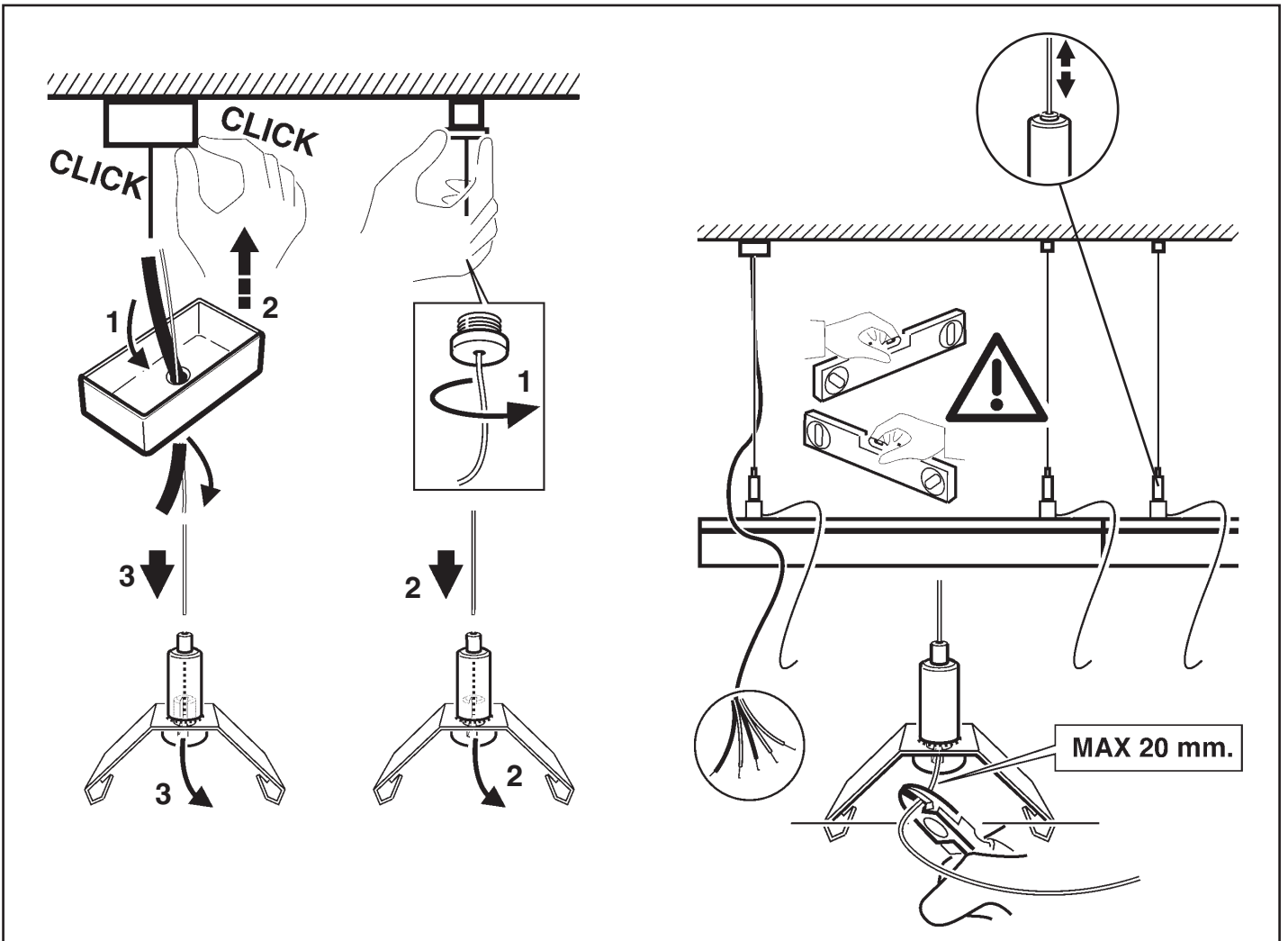
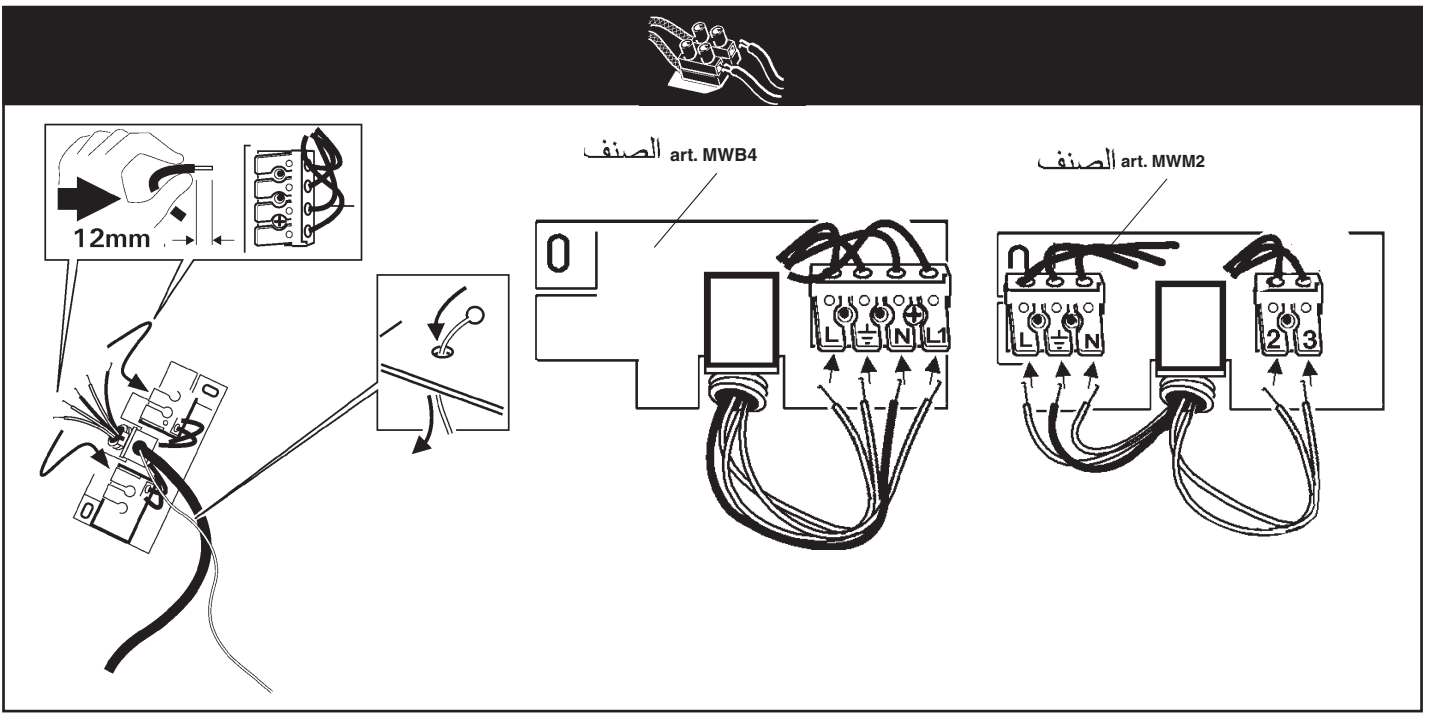

iGuzzini 2.510.113.01 IS11381/01 ART.	corrente assorbita absorbed current courant absorbé Stromaufnahme stroomopname corriente absorbida absorberet strøm absorbert strøm tillförd ström поглощаемая мощность 电源电流 A	fattore di potenza power factor facteur de puissance Leistungsfaktor vermogensfactor factor de potencia effektfaktor effektfaktor effektfaktor фактор мощности 功率因数 λ
Q388 - Q390 - Q392 - Q394 - Q406 - Q409 Q389 - Q391 - Q393 - Q395 - Q412 - Q415	0,15	>0,95
Q404 - Q410	0,08	>0,95
Q405 - Q411	0,12	>0,95
Q407 - Q413	0,08	0,95
Q408 - Q414	0,11	>0,95
Q416 - Q417 - Q418 - Q419	0,23	>0,95
Q436 - Q438 - Q440 - Q442 Q437 - Q439 - Q441 - Q443	0,07	>0,95
Q444 - Q450	0,04	>0,9
Q445 - Q451	0,06	>0,95
Q446 - Q452	0,07	>0,95
Q447 - Q453	0,05	0,9
Q448 - Q454	0,06	0,9
Q449 - Q455	0,07	>0,9
Q456 - Q458 Q457 - Q459	0,11	>0,95
QH85 - QH87	0,46	>0,95
QH86 - QH88	0,45	>0,95
QH89 - QH91	0,67	>0,95
QH90 - QH92	0,66	>0,95
QH93 - QH95	0,2	>0,95
QH94 - QH96	0,2	>0,95
QH97 - QH99	0,31	>0,95
QH98 - QI00	0,3	>0,95

iGuzzini 2.510.113.01 IS11381/01 ART.	corrente assorbita absorbed current courant absorbé Stromaufnahme stroomopname corriente absorbida absorberet strøm absorbert strøm tillförd ström поглощаемая мощность 电源电流 A	fattore di potenza power factor facteur de puissance Leistungsfaktor vermogensfactor factor de potencia effektfaktor effektfaktor effektfaktor фактор мощности 功率因数 λ
Q388 - Q390 - Q392 - Q394 - Q406 - Q409 Q389 - Q391 - Q393 - Q395 - Q412 - Q415	0,15	>0,95
Q404 - Q410	0,08	>0,95
Q405 - Q411	0,12	>0,95
Q407 - Q413	0,08	0,95
Q408 - Q414	0,11	>0,95
Q416 - Q417 - Q418 - Q419	0,23	>0,95
Q436 - Q438 - Q440 - Q442 Q437 - Q439 - Q441 - Q443	0,07	>0,95
Q444 - Q450	0,04	>0,9
Q445 - Q451	0,06	>0,95
Q446 - Q452	0,07	>0,95
Q447 - Q453	0,05	0,9
Q448 - Q454	0,06	0,9
Q449 - Q455	0,07	>0,9
Q456 - Q458 Q457 - Q459	0,11	>0,95
QH85 - QH87	0,46	>0,95
QH86 - QH88	0,45	>0,95
QH89 - QH91	0,67	>0,95
QH90 - QH92	0,66	>0,95
QH93 - QH95	0,2	>0,95
QH94 - QH96	0,2	>0,95
QH97 - QH99	0,31	>0,95
QH98 - QI00	0,3	>0,95